

MX412 & MXL412 Pump & Packages



Patent 7,603,855

ADDITIONAL RESOURCES

For additional information or copies of your service manual, please visit us online at:

binks.com/en/library

Obey local or municipal regulations for product recycling and disposal.

IMPORTANT! DO NOT DESTROY
It is the Customer's responsibility to have all operators and service personnel read and understand this manual.
Contact your local Binks representative for additional copies of this manual.
READ ALL INSTRUCTIONS BEFORE OPERATING THIS PRODUCT

Product Description / Object of Declaration:	104XXX, AX160L-X, AX110L-X, AX200L-XX, AX260L-XX, AX320X-X, MMX4****, MMX12****, MXL4****, MXL12****, MX114****, MX12****, MX19****, MX2****, MX4****, MX8****
This Product is designed for use with:	Solvent & Waterbased Materials
Suitable for use in hazardous area:	Zone 1/Zone 2
Protection Level:	II 2 G c X IIB T4 Ex h IIB T4 Gb X
Notified body details and role:	Element Materials Technology Rotterdam B.V. (2812)
	Lodging of ATEX Technical file
This Declaration of Conformity / Incorporation is issued under the sole responsibility of the manufacturer:	Binks U.K. Limited, Ringwood Road, Bournemouth, BH11 9LH. UK
Representative authorised to compile the technical file	President @. Binks France SAS 5 Place Pierre Semard, 94130 Nogent sur Marne , Paris, France

EU Declaration of Conformity



This Declaration of Conformity / Incorporation is issued under the sole responsibility of the manufacturer:

Machinery Directive 2006/42/EC

ATEX Directive 2014/34/EU

by complying with the following statutory documents and harmonised standards:

EN ISO 12100:2010 Safety of Machinery - General Principles for Design

EN 12621:2006+2010 Machinery for the supply and circulation of coating materials under pressure - Safety requirements

EN ISO 80079-36:2016 Explosive Atmospheres- Part 36:Non Electrical equipment for explosive atmospheres-Basic methods and requirements.

EN ISO 80079-37:2016 Explosive Atmospheres- Part 37: Non Electrical equipment for explosive atmospheres - protection by methods "c", "b" and "k".

EN 1127-1:2019 Explosive atmospheres - Explosion prevention - Basic concepts

Providing all conditions of safe use / installation stated within the product manuals have been complied with and also installed in accordance with any applicable local codes of practice.

Signed for and on behalf of Binks
U.K. Ltd:

Document Part No.

. EN

F. A. Sutter

22/04/2025

Executive President: Engineering and
Operations, Shoreview, MN, 55126. USA

Product Description / Object of Declaration:	104XXX, AX160L-X, AX110L-X, AX200L-XX, AX260L-XX, AX320X-X, MMX4****, MMX12****, MXL4****, MXL12****, MX114****, MX12****, MX19****, MX2****, MX4****, MX8****
This Product is designed for use with:	Solvent & Waterbased Materials
Suitable for use in hazardous area:	Zone 1/Zone 2
Protection Level:	II 2 G c X IIB T4 Ex h IIB T4 Gb X
Approved body details and role:	Element Materials Technology Warwick Ltd. UK. (0891)
	Lodging of UKEX Technical file
This Declaration of Conformity / Incorporation is issued under the sole responsibility of the manufacturer:	Binks U.K. Limited, Ringwood Road, Bournemouth, BH11 9LH. UK

UKCA Declaration of Conformity

**UK
CA**



This Declaration of Conformity / Incorporation is issued under the sole responsibility of the manufacturer:



Supply of Machinery (Safety) Regulations 2008
 Equipment and Protective Systems Intended for use in Potentially Explosive Atmospheres Regulations 2016
 by complying with the following statutory documents and designated standards:
 BS EN ISO 12100:2010 Safety of Machinery - General Principles for Design
 BS EN 12621:2006+2010 Machinery for the supply and circulation of coating materials under pressure - Safety requirements
 BS EN ISO 80079-36:2016 Explosive Atmospheres- Part 36:Non Electrical equipment for explosive atmospheres-Basic methods and requirements.
 BS EN ISO 80079-37:2016 Explosive Atmospheres- Part 37: Non Electrical equipment for explosive atmospheres - protection by methods "c", "b" and "k".
 BS EN 1127-1:2019 Explosive atmospheres - Explosion prevention - Basic concepts

Providing all conditions of safe use / installation stated within the product manuals have been complied with and also installed in accordance with any applicable local codes of practice.

Signed for and on behalf of Binks U.K. Ltd:	 F. A. Sutter 20/05/2025	Executive President: Engineering and Operations, Shoreview, MN, 55126. USA
Document Part No. . EN		

In this part sheet, the words WARNING, CAUTION and NOTE are used to emphasize important safety information as follows:

EN

 WARNING	 CAUTION	NOTE
Hazards or unsafe practices which could result in severe personal injury, death or substantial property damage.	Hazards or unsafe practices which could result in minor personal injury, product or property damage	Important installation, operation or maintenance information.
 WARNING		

Read the following warnings before using this equipment.



READ THE MANUAL. Before operating finishing equipment, read and understand all safety, operation and maintenance information provided in the operation manual.



AUTOMATIC EQUIPMENT. Automatic equipment may start suddenly without warning.



WEAR SAFETY GLASSES. Failure to wear safety glasses with side shields could result in serious eye injury or blindness.

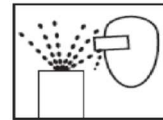

PROJECTILE HAZARD. You may be injured by venting liquids or gases that are released under pressure, or flying debris.



DE-ENERGIZE, DE-PRESSURISE, DISCONNECT AND LOCK OUT ALL POWER SOURCES DURING MAINTENANCE. Failure to de-energize, disconnect and lock out all power supplies before performing equipment maintenance could cause serious injury or death.



KNOW WHERE AND HOW TO SHUT OFF THE EQUIPMENT IN CASE OF AN EMERGENCY.



NOISE LEVELS. The A-weighted sound level of pumping and spray equipment may exceed 85 dB(A) depending on equipment settings. Actual noise levels are available on request. It is recommended that ear protection is worn at all times while equipment is in use.



PRESSURE RELIEF PROCEDURE. Always follow the pressure relief procedure in the equipment instruction manual.



INSPECT THE EQUIPMENT DAILY. Inspect the equipment for worn or broken parts on a daily basis. Do not operate the equipment if you are uncertain about its condition.

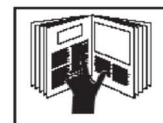

OPERATOR TRAINING. All personnel must be trained before operating finishing equipment.



EQUIPMENT MISUSE HAZARD. Equipment misuse can cause the equipment to rupture, malfunction or start unexpectedly and result in serious injury.



PACEMAKER WARNING. You are in the presence of magnetic fields which may interfere with the operation of certain pacemakers.



HIGH PRESSURE CONSIDERATION. High pressure can cause serious injury. Relieve all pressure before servicing. Spray from the gun, hose leaks or ruptured components can inject fluid into your body and cause extremely serious injury.



KEEP EQUIPMENT GUARDS IN PLACE. Do not operate the equipment if the safety devices have been removed.



STATIC CHARGE. Fluid may develop a static charge that must be dissipated through proper grounding of the equipment, objects to be sprayed and all other electrically conductive objects in the dispensing area. Improper grounding or sparks can cause a hazardous condition and result in fire, explosion or electric shock and other serious injury.



NEVER MODIFY THE EQUIPMENT. Do not modify the equipment unless the manufacturer provides written approval.



PROP 65 WARNING. WARNING: This product contains chemicals known to the state of California to cause cancer and birth defects or other reproductive harm.



PINCH POINT HAZARD. Moving parts can crush and cut. Pinch points are any areas where there are moving parts.

IT IS THE RESPONSIBILITY OF THE EMPLOYER TO PROVIDE THIS INFORMATION TO THE OPERATOR OF THE EQUIPMENT.

Models: MX412## & MXL412##, ##=PL (PTFE/Leather), PP (PTFE), PU (PTFE/UHMWPE), UC (U-Cups)

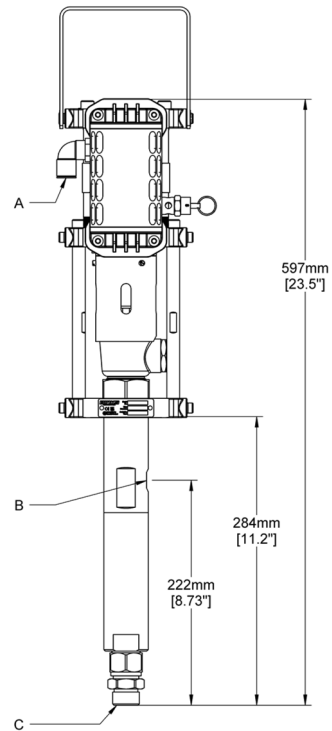

Patent 7,603,855

SPECIFICATION - Bare Pump

	Ratio:	12:1
	Maximum air inlet pressure:	8 bar [116 psi]
	Maximum fluid pressure:	96 bar [1390 psi]
	Displacement per cycle:	24 cc [0.8 oz]
	Output @ 60 cycles / min:	1.4 l/m [0.4 US gal/m]
	Air consumption @ 20 cycles/min and 8 bar [116 psi] air inlet pressure:	62.5 l/m [2.2 SCFM]
	Maximum recommended continuous cycle rate [cycles/min]:	20
A	Air inlet connection:	Ø12mm Hose
C	Fluid inlet connection:	MX-3/4" NPS (m), MXL-1/2" NPS (m)
B	Fluid outlet connection:	MX-M14x1.5(f), MXL-3/8" BSP/NPS(m)
Air Quality ISO 8573-1 Class 3.4.2 :		
Dirt: Maximum 1000 particles per cubic metre size 1 - 5µm and maximum 90000 particles per cubic metre size 0.5 - 1µm		
Water: +3°C @ 8 Bar maximum vapour pressure dewpoint		
Oil: 0.1 0.1 milligrams per cubic metre maximum aerosol liquid and vapour		
	Sound level:	88 dB
	Weight:	7.5 kg [16.5 lbs]
	Wetted parts materials of construction:	Stainless Steel, Tungsten Carbide, PTFE, Polyethylene, Leather, Ceramic.

PUMP OPERATION AND CLEANING

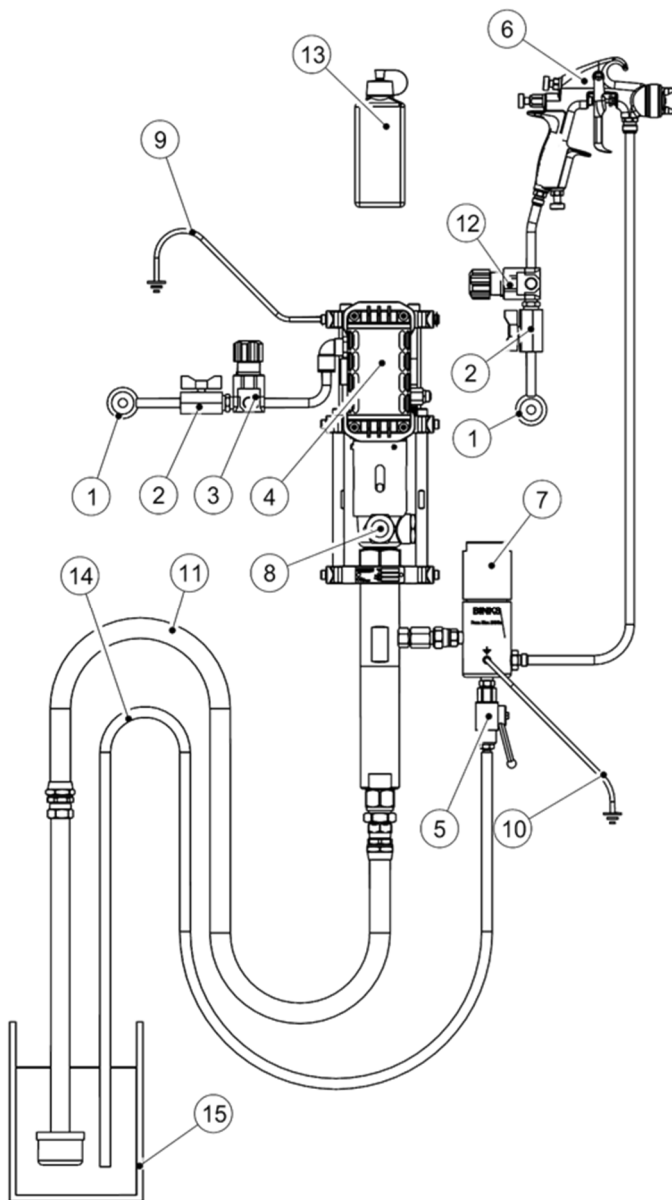

1	AIR SUPPLY
2	AIR SHUT OFF VALVE (IF FITTED)
3	AIR PRESSURE REGULATOR
4	BINKS PUMP
5	FLUID PRESSURE RELIEF VALVE (IF FITTED)
6	SPRAY GUN
7	FLUID FILTER (IF FITTED)
8	LUBRICATION CUP & LEVEL
9	EARTH CABLE AIR MOTOR
10	EARTH CABLE FLUID FILTER (IF FITTED)
11	FLUID SUCTION HOSE/SUCTION TUBE/GRAVITY HOPPER - DEPENDING ON MODEL
12	AIR PRESSURE REGULATOR (SPRAY GUN) (IF FITTED)
13	LUBRICANT 0114-016099 SOLVENT BASED MATERIALS 0114-016100 WATER BASED MATERIALS
14	RELIEF/RETURN HOSE (IF FITTED)
15	FLUID CONTAINER

WARNING

WEAR EYE PROTECTION WHEN OPERATING THIS EQUIPMENT

WARNING

PUMP MUST BE GROUNDED BEFORE OPERATING, TO PREVENT STATIC CHARGES.

WARNING

HOSES MUST HAVE A SUITABLE WORKING PRESSURE ABOVE THE MAXIMUM PRESSURE POSSIBLE.

INSTALLATION

1. ENSURE THE PUMP IS LOCATED ON A SUITABLE & STABLE MOUNTING.
2. GROUND/EARTH THE PUMP WITH (9) OR (10), CHECK EARTH IS LESS THAN 1 Ohm.
3. CONNECT SUITABLE HOSES FOR AIR SUPPLY AND FLUID HOSE TO GUN.
4. FILL THE LUBRICATION CUP (8) WITH A SUITABLE LUBRICANT (13) SO IT IS VISIBLE IN THE LEVEL SIGHT GLASS.
5. ENSURE SUITABLE FILTER MESH (100 MESH, 150 μ m STD) IS INSTALLED IN THE FILTER(7).
6. ENSURE RETURN HOSE (14) IF FITTED, IS DIRECTED INTO THE FLUID CONTAINER (15).

CLEANING THE PUMP

NOTE	THE PUMP HAS BEEN TESTED WITH OIL, WATER OR OTHER MATERIAL. CLEAN THE PUMP PRIOR TO USE TO AVOID ANY CONTAMINATION.
-------------	---

1. INSERT SUCTION SYSTEM (11) & RETURN HOSE (14) (IF FITTED) INTO A CONTAINER WITH SUITABLE CLEANING FLUID.
2. CLOSE VALVE (2) AND SET REGULATORS (3) & (12) TO ZERO (WIND ANTICLOCKWISE), OPEN VALVE (5) IF FITTED.
3. REMOVE FLUID NOZZLE FROM THE SPRAY GUN FOR RETURNING FLUID INTO THE CONTAINER.
4. CONNECT AIR SUPPLY.
 - a) IF (5) IS FITTED:
- 5a. OPEN VALVE (2), INCREASE REGULATOR PRESSURE (3) UNTIL PUMP STARTS TO OPERATE.
- 6a. ALLOW FLUID TO CIRCULATE FOR SEVERAL MINUTES OR UNTIL SYSTEM IS CLEAN.
- 7a. CLOSE VALVE (5) AND TRIGGER SPRAY GUN INTO CONTAINER FOR SEVERAL MINUTES TO CLEAN HOSE & GUN.
- 8a. WITH THE TRIGGER STILL OPEN REDUCE REGULATOR PRESSURE (3) TO ZERO, AND OPEN VALVE (5) IF FITTED AND CLOSE TRIGGER.
 - b) IF (5) IS NOT FITTED.
- 5b. TRIGGER SPRAY GUN AND HOLD OVER CONTAINER, OPEN VALVE (2), INCREASE REGULATOR PRESSURE (3) UNTIL PUMP STARTS TO OPERATE.
- 6b. ALLOW FLUID TO CIRCULATE FOR SEVERAL MINUTES OR UNTIL SYSTEM IS CLEAN.
- 7b. WITH THE TRIGGER STILL OPEN REDUCE REGULATOR PRESSURE(3) TO ZERO AND ENSURE NO PRESSURE IS LEFT IN THE HOSE AND GUN BEFORE CLOSING THE TRIGGER.

NOTE	REPEAT CLEANING PROCESS UNTIL CLEANING FLUID HAS NO CONTAMINATION, ESPECIALLY IF THE PUMP WILL NOT BE USED IMMEDIATELY, OR HAS BEEN USED WITH 2 COMPONENT PAINTS.
 CAUTION	WHEN THE SPRAY GUN IS NOT IN USE THE SAFETY LOCK SHOULD BE ENGAGED TO PREVENT ACCIDENTAL OPERATION.

STARTUP

1. INSERT SUCTION SYSTEM (11) & RETURN HOSE (14) (IF FITTED) INTO A CONTAINER WITH THE FLUID TO BE SPRAYED
2. CLOSE VALVE (2) AND SET REGULATORS (3) & (12) TO ZERO (WIND ANTICLOCKWISE), OPEN VALVE (5) IF FITTED.
3. REMOVE SPRAY TIP FROM THE GUN FOR RETURNING FLUID INTO THE CONTAINER.
4. CONNECT AIR SUPPLY
 - a) IF (5) IS FITTED:
 - 5a. OPEN VALVE (2), INCREASE REGULATOR PRESSURE (3) UNTIL PUMP STARTS TO OPERATE.
 - 6a. WHEN FLUID FLOWS THROUGH HOSE (14) WITHOUT AERATION, CLOSE VALVE (5).
 - 7a. OPEN SPRAY GUN TRIGGER UNTIL FLUID FLOWS INTO CONTAINER WITHOUT AIR, THEN RELEASE TRIGGER.
 - b) IF (5) IS NOT FITTED.
 - 5b. TRIGGER SPRAY GUN AND HOLD OVER CONTAINER, OPEN VALVE (2), INCREASE REGULATOR PRESSURE (3) UNTIL PUMP STARTS TO OPERATE.
 - 6b. KEEP TRIGGER OPEN UNTIL FLUID FLOWS INTO CONTAINER WITHOUT AERATION, THEN RELEASE TRIGGER.
8. REDUCE REGULATOR PRESSURE (3) TO ZERO.
9. APPLY SPRAY GUN SAFETY LOCK WHILE SPRAY TIP IS FITTED.
10. INCREASE REGULATOR PRESSURE (3) UNTIL DESIRED ATOMISATION IS ACHIEVED FROM SPRAY GUN.
11. INCREASE REGULATOR PRESSURE (12) TO ACHIEVE DESIRED SPRAY FAN.

SHUT DOWN

1. REDUCE REGULATOR PRESSURE (3) AND (12) TO ZERO.
2. TRIGGER GUN TO REDUCE SYSTEM PRESSURE.
3. OPEN VALVE (5) SLOWLY IF FITTED.
4. APPLY SPRAY GUN SAFETY LOCK WHILE SPRAY TIP IS REMOVED
5. TRIGGER GUN CAREFULLY INTO CONTAINER AND ENSURE FLUID SYSTEM IS DE-PRESSURISED.
6. CLOSE VALVE (2) AND REMOVE AIR SUPPLY.
7. APPLY SPRAY GUN SAFETY LOCK.
8. CLEAN AS INSTRUCTED AND SOAK/CLEAN SPRAYGUN FLUID NOZZLE.

NOTE	IF THE SYSTEM IS NOT USED FOR AN EXTENDED PERIOD IT IS RECOMMENDED TO BE FILLED WITH A LIGHT OIL AFTER CLEANING.
-------------	--

ATEX special conditions for safe use:

Pump Earthing

The pump must be earthed at all times. A resistance $<1\Omega$ when measuring with an ohm-meter at the earth point

Earth connection, Binks Part No. 0114-011798

MX412 & MXL412 BARE PUMP

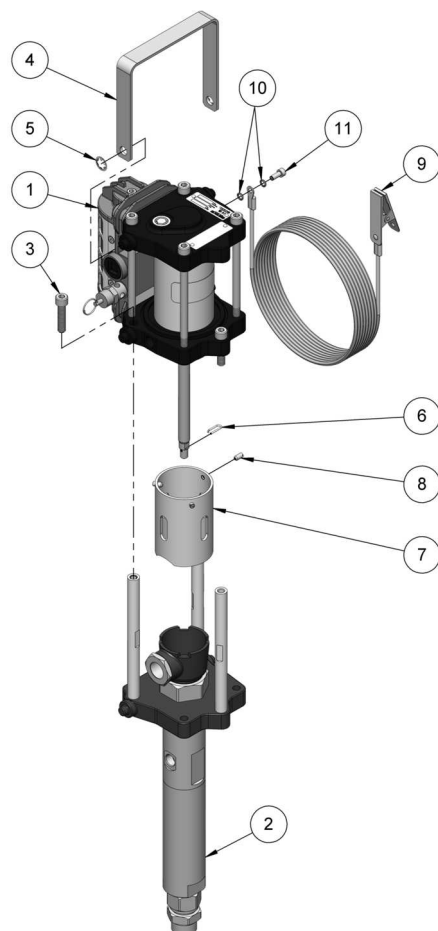

ITEM	PART NUMBER	DESCRIPTION	QUANTITY			
			MX412 / MXL412			
			PL	PP	PU	UC
1	AX55S	AIR MOTOR	1	1	1	1
2	FX4PL/FXL4PL	FLUID SECTION (PTFE/LEATHER)	1	-	-	-
	FX4PP/FXL4PP	FLUID SECTION (PTFE)	-	1	-	-
	FX4PU/FXL4PU	FLUID SECTION (PTFE/UHMW)	-	-	1	-
	FX4UC/FXL4UC	FLUID SECTION (U-CUPS)	-	-	-	1
3 Δ	0115-010001	SOCKET HEAD CAP SCREW	3	3	3	3
4	0114-014351	HANDLE	1	1	1	1
5	0115-010272	RETAINING RING	2	2	2	2
6 •	0115-010099	ROD CLIP	1	1	1	1
7	0115-010655	GUARD	1	1	1	1
8	166001	SLOTTED SET SCREW	3	3	3	3
9	0114-011798	GROUND WIRE	1	1	1	1
10	0114-009743	SPRING WASHER	2	2	2	2
11	0114-014179	SOCKET HEAD CAP SCREW	1	1	1	1

• Part only available in repair kits: 0115-010220, 0115-010222, 0115-010388 and 0115-010224.

Δ Part only available in AX55 Hardware kit: 0115-010213.

MX412 & MXL412 - BARE PUMP - MAINTENANCE

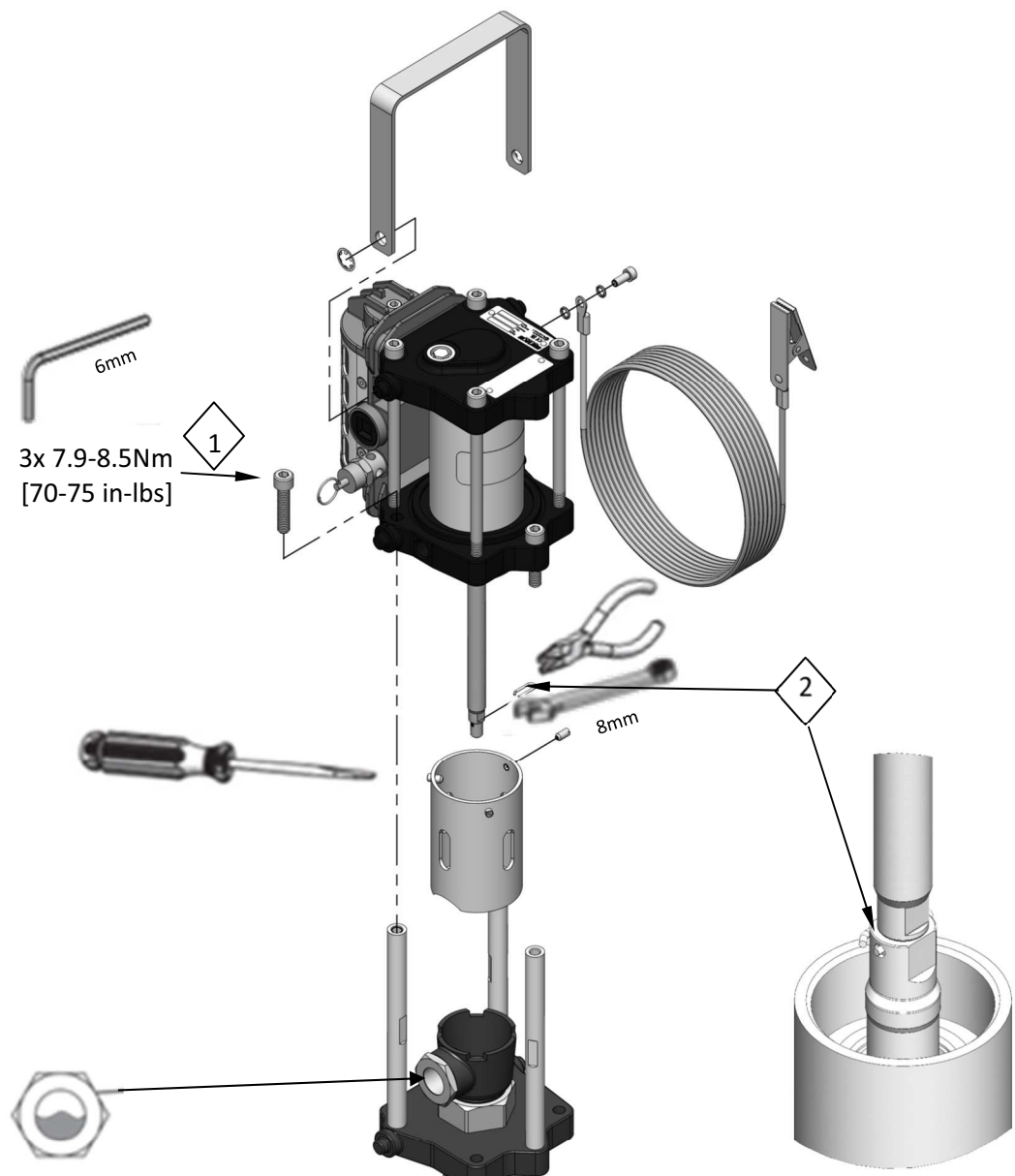

RECOMMENDED LUBRICANT LEVEL

MAINTENANCE SYMBOLS

#	ITEM NUMBER
#	DISASSEMBLY ORDER (Reverse for assembly)
PG	PETROLEUM JELLY/GREASE
TS	THREAD SEALANT (PTFE tape)

MX412 & MXL412 - BARE PUMP - TROUBLESHOOTING

PROBLEM	CAUSE	SOLUTION
Pump will not start	No compressed air.	Check compressed air supply.
	Spray tip is blocked.	Clean or replace the spray tip.
Erratic operation of air motor, air motor stops.	Worn poppet assemblies.	Replace poppet assemblies.
	Worn or dirty spool and sleeve assembly.	Clean or replace the spool and sleeve assembly as necessary.
Continuous air leak from the exhaust	Worn poppet assemblies.	Replace poppet assemblies.
	Worn piston seal.	Replace piston seal.
	Worn diaphragm.	Replace diaphragm.
Material in solvent cup.	Worn or dirty upper packings.	Replace or clean upper packings as necessary.
Pump does not stop on the down stroke	Worn or dirty lower ball check.	Replace or clean the parts as necessary.
Pump does not stop on the up stroke	Worn or dirty upper ball check.	Replace or clean the parts as necessary.
	Worn or dirty lower packings.	
Pump runs erratically	Blocked siphon kit.	Replace or clean the siphon kit.
	Blocked inlet filter or strainer.	Replace or clean inlet filter or strainer.
	Low material level.	Replace or refill material container.
Pump runs, with no output	Loose connection in between pump and siphon assembly.	Check that all connections are tight.
	Stuck lower ball.	Replace or clean the parts as necessary.

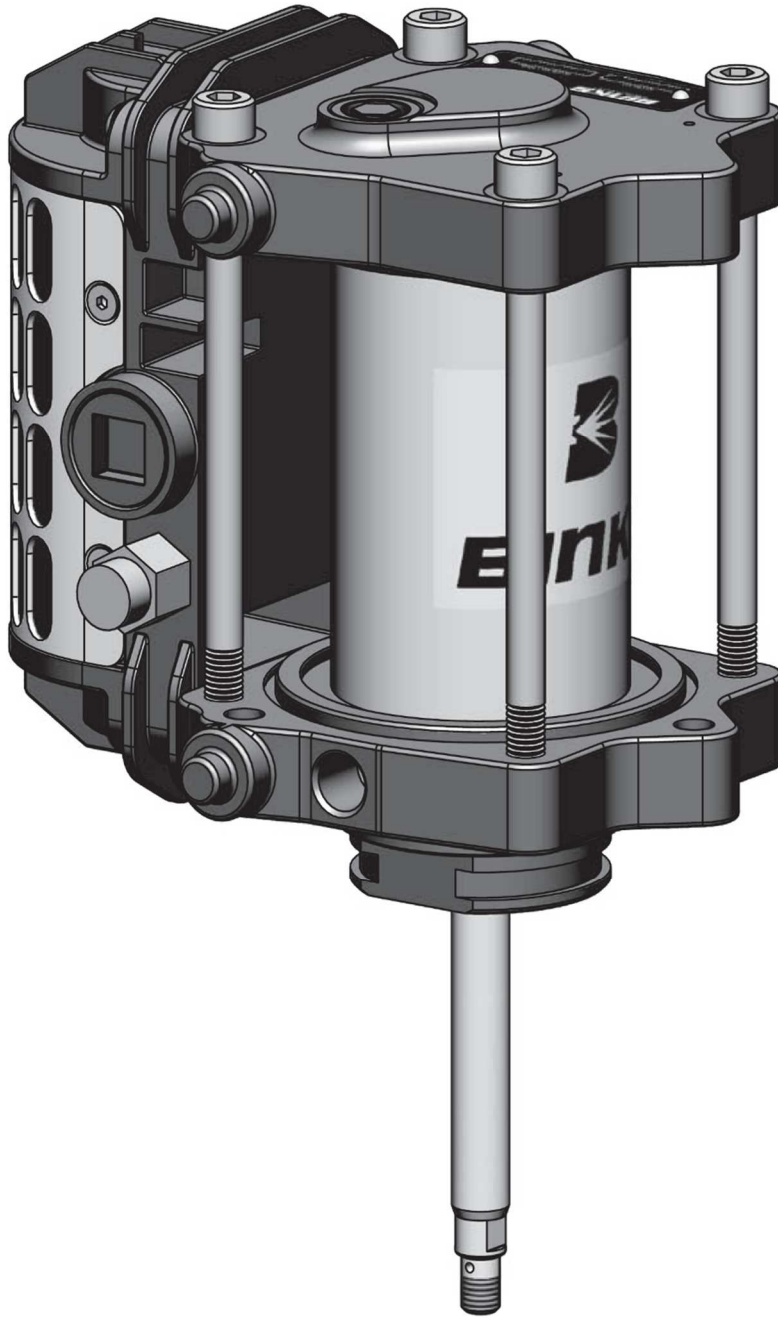
AX55S AIR MOTOR**Patent 7,603,855**

SPECIFICATION	
Maximum air inlet pressure:	8 bar [116 psi]
Maximum recommended continuous cycle rate [cycles/min]:	20
Air inlet connection:	Ø12mm Hose
Piston Diameter:	55 mm [2.2 in]
Stroke length:	75 mm [3.0 in]

AX55S AIR MOTOR

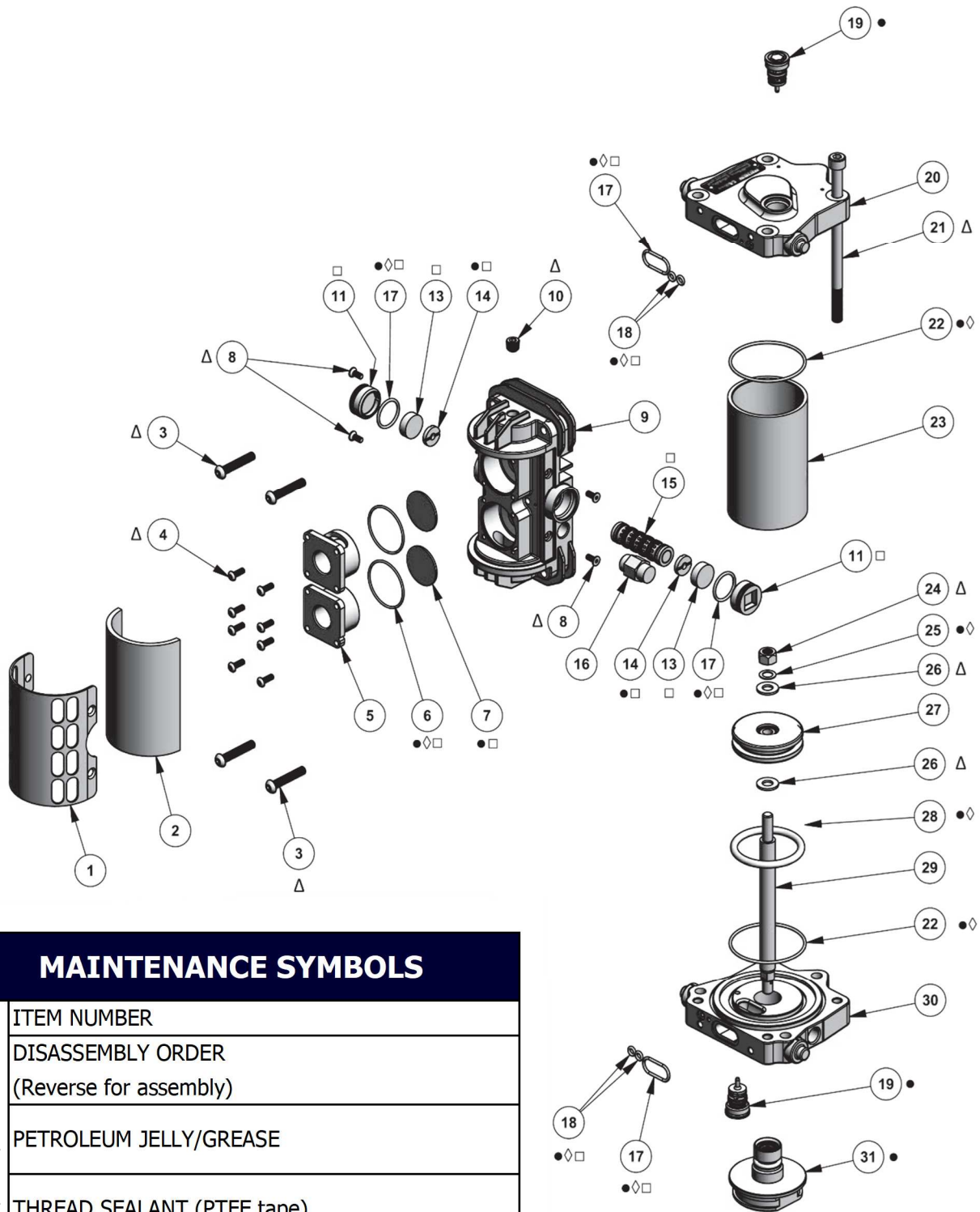

MAINTENANCE SYMBOLS

#	ITEM NUMBER
#	DISASSEMBLY ORDER (Reverse for assembly)
PG	PETROLEUM JELLY/GREASE
TS	THREAD SEALANT (PTFE tape)

- Parts are included in 0115-010214 AX55 Repair Kit.
- ◆ Parts are included in 0115-010216 AX55 Seal Kit.
- Parts are included in 0115-010226 Air Motor Valve Repair Kit.
- ▲ Parts are included in 0115-010213 AX55 Hardware Kit.

AX55S AIR MOTOR

REF.	PART NUMBER	DESCRIPTION	QTY	
1	○	0115-010023	EXHAUST COVER SCREEN	1
2	○	0115-010022	EXHAUST COVER	1
3	○△	0115-010026	BUTTON HEAD CAP SCREW	4
4	○△	0115-010073	BUTTON HEAD CAP SCREW	8
5	○	0115-010019	QUICK EXHAUST VALVE CAGE	2
6	○●◇□	0115-010021	O-RING	2
7	○●□	0115-010020	DIAPHRAGM	2
8	○	0115-010024	COUNTER SUNK CAP SCREW	4
9	○	0115-010097	VALVE BLOCK	1
10	○△	0115-010107	PIPE PLUG	1
11	○□	0115-010018	VALVE BLOCK END CAP	2
13	○□	0115-010017	MAGNET	2
14	○●□	0115-010016	BUMPER	2
15	○□	0115-010015	SPOOL AND SLEEVE ASSEMBLY	1
16	○	0114-014774	SAFETY VALVE	1
17	○●◇□	0115-010049	O-RING	4
18	●◇□	0115-010051	O-RING	4
19	●	0115-010037	POPPET ASSEMBLY	2
20		0115-010004	UPPER END CAP MACHINING	1
21	△	0115-010029	SOCKET HEAD CAP SCREW	4
22	●◇	0115-010086	CYLINDER SEAL, 55mm	2
23		0115-010007	CYLINDER, 55mm	1
24	△	0115-010096	LOCKNUT	1
25	●◇	0115-010036	SEALING RING	1
26	△	0115-010035	FLAT WASHER	2
27		0115-010085	PISTON, 55mm	1
28	●◇	0115-010025	PISTON SEAL, 55mm	1
29		0115-010034	MOTOR ROD	1
30		0115-010006	LOWER END CAP MACHINING	1
31	●	0115-010657	MOTOR ROD CARTRIDGE ASSEMBLY	1
32		0115-010181	90° SWIVEL ELBOW, Ø12mm TUBE - G3/8" MALE (not shown)	1

○ Items available separately or as a complete assembly: 0115-010660.

● Parts are included in 0115-010214 AX55 Repair Kit.

◇ Parts are included in 0115-010216 AX55 Seal Kit.

□ Parts are included in 0115-010226 Air Motor Valve Repair Kit.

△ Parts are included in 0115-010213 AX55 Hardware Kit.

AX55S AIR MOTOR - MAINTENANCE

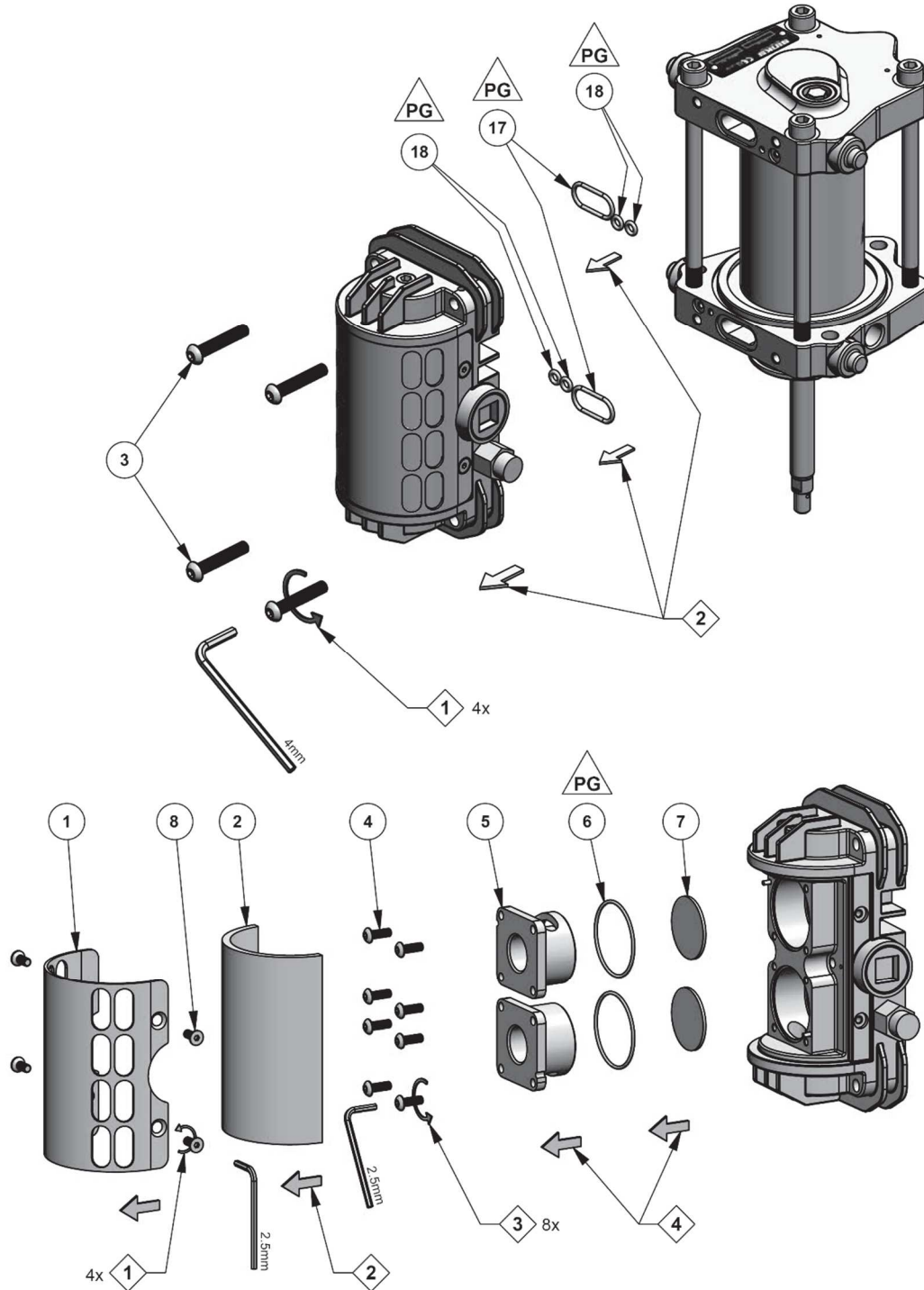

MAINTENANCE SYMBOLS

#	ITEM NUMBER
#	DISASSEMBLY ORDER (Reverse for assembly)
PG	PETROLEUM JELLY/GREASE
TS	THREAD SEALANT (PTFE tape)

AX55S AIR MOTOR - MAINTENANCE

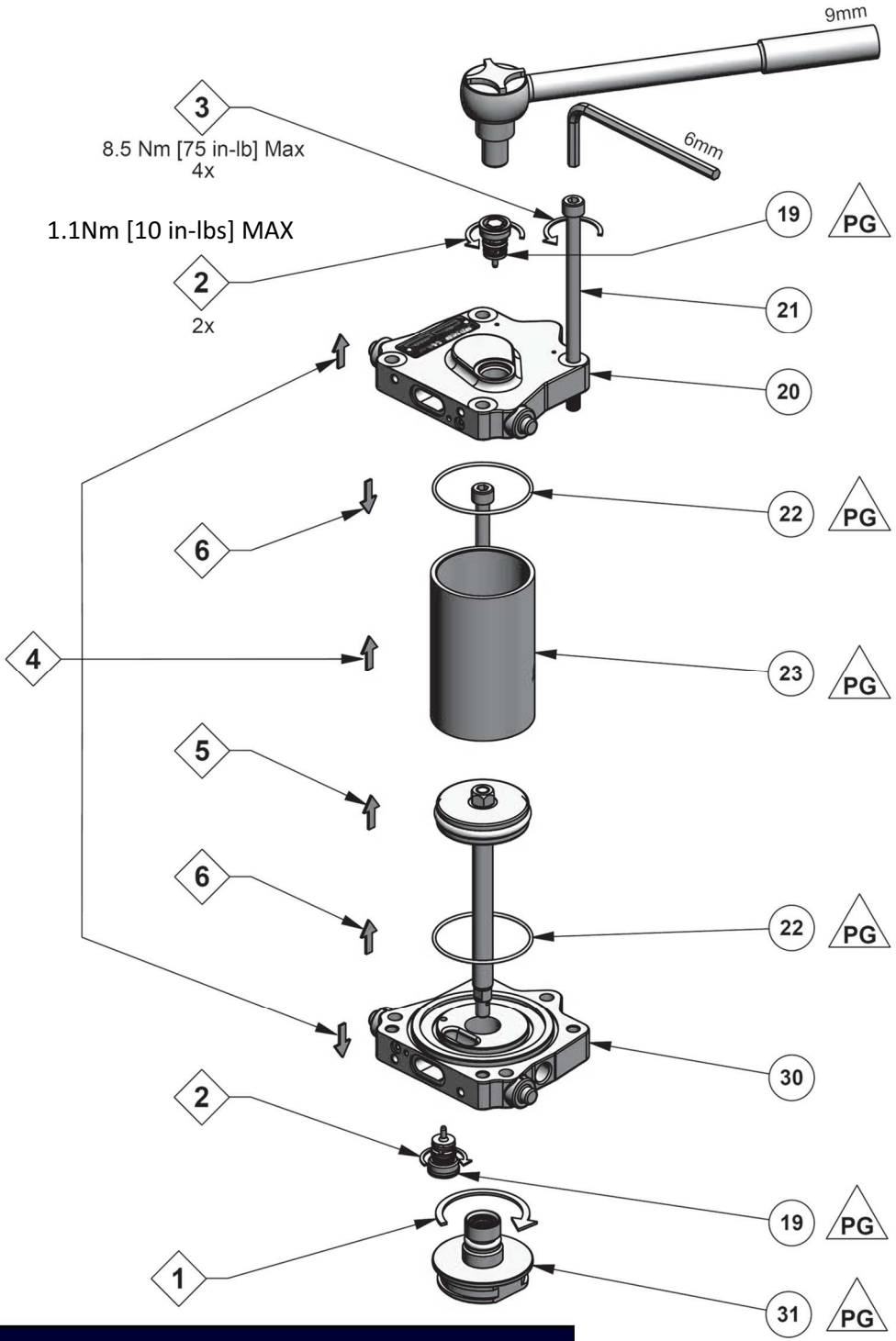

MAINTENANCE SYMBOLS	
#	ITEM NUMBER
#	DISASSEMBLY ORDER (Reverse for assembly)
PG	PETROLEUM JELLY/GREASE
TS	THREAD SEALANT (PTFE tape)

AX55S AIR MOTOR - MAINTENANCE

MAINTENANCE SYMBOLS

#	ITEM NUMBER
#	DISASSEMBLY ORDER (Reverse for assembly)
PG	PETROLEUM JELLY/GREASE
TS	THREAD SEALANT (PTFE tape)

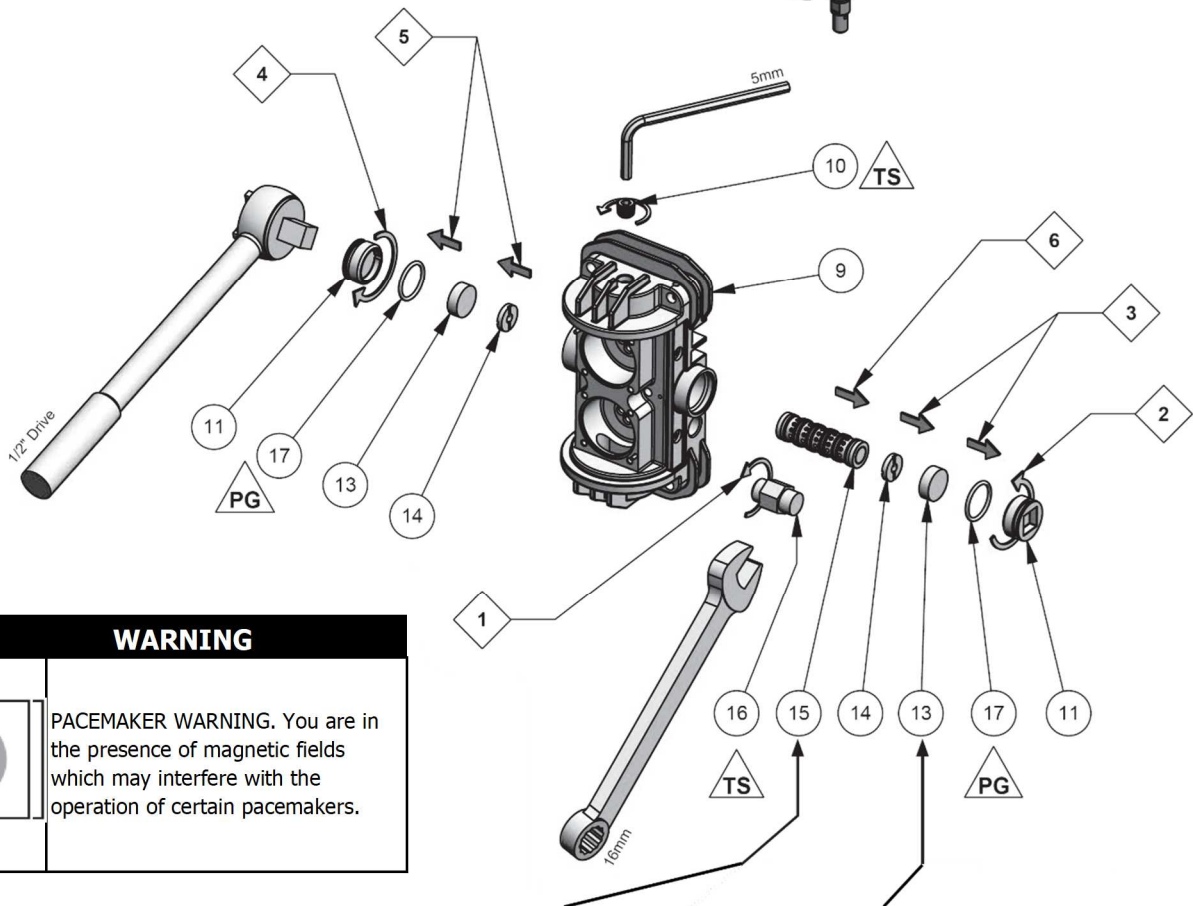
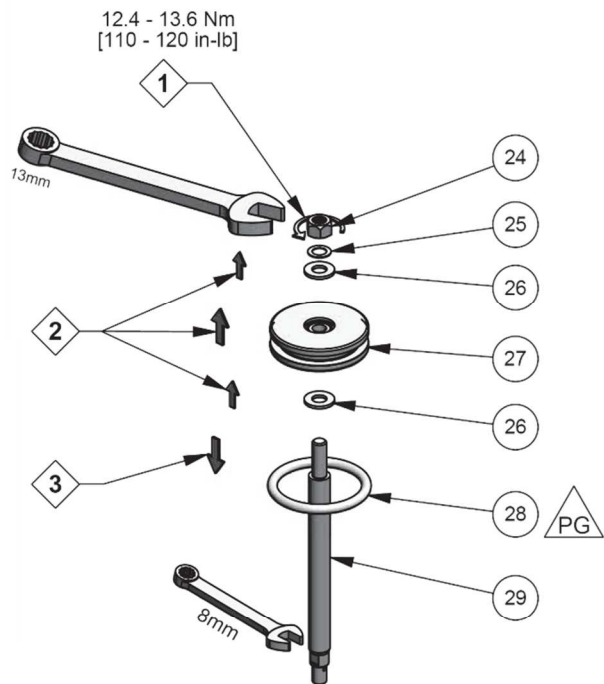

	WARNING
	PACEMAKER WARNING. You are in the presence of magnetic fields which may interfere with the operation of certain pacemakers.

NOTE	CAUTION
Spool and sleeve assembly (15) is a matched set and cannot be interchanged with other spool and sleeve assemblies	Take care when handling the magnets (13). Avoid getting magnets in close proximity to each other. Injury or damage to magnets may result.

AX55S AIR MOTOR - TROUBLESHOOTING

PROBLEM	CAUSE	SOLUTION
Pump will not start	No compressed air.	Check compressed air supply.
	System is blocked.	Clear the blockage.
Erratic operation of air motor, air motor stops.	Worn poppet assemblies.	Replace poppet assemblies.
	Worn or dirty spool and sleeve assembly.	Clean or replace the spool and sleeve assembly as necessary.
Continuous air leak from the exhaust	Worn poppet assemblies.	Replace poppet assemblies.
	Worn piston seal.	Replace piston seal.
	Worn diaphragm.	Replace diaphragm.

NOTES

FX4 AND FXL4 - Fluid Section

Models: FX4## & FXL4##, ##=PL (PTFE/Leather), PP (PTFE), PU (PTFE/UHMWPE), UC (U-Cups)

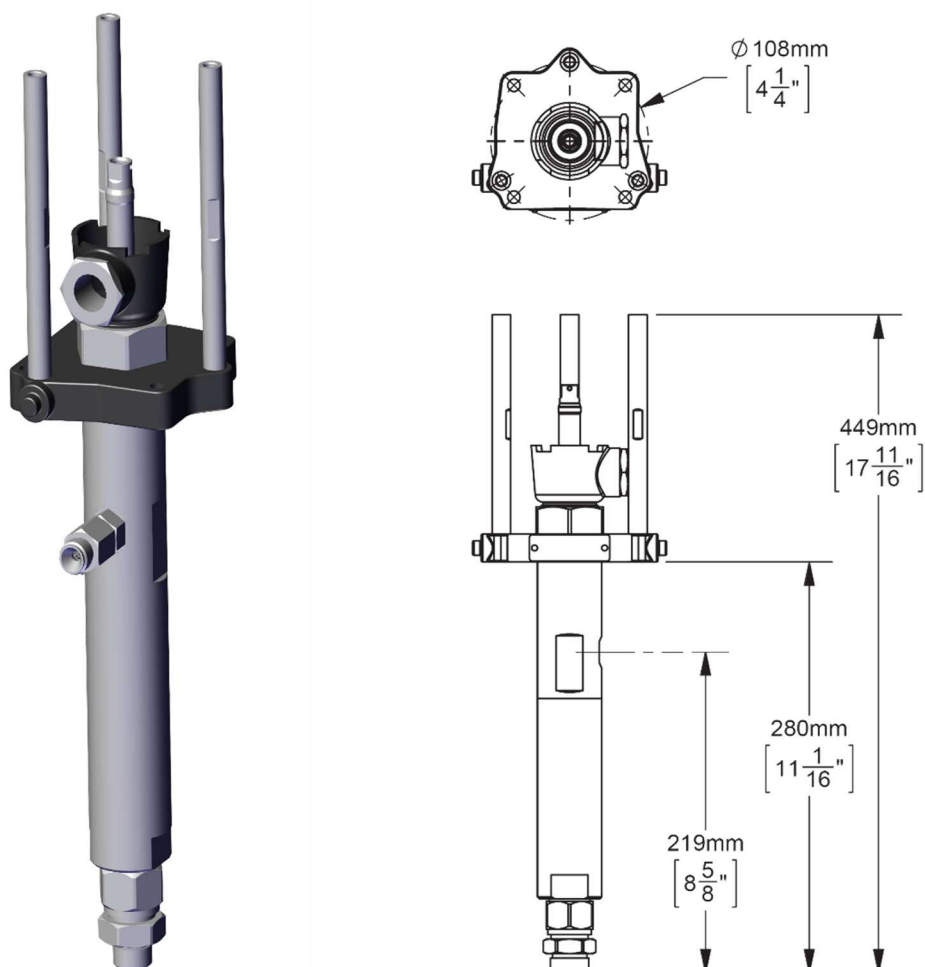

SPECIFICATION

Maximum fluid pressure:	256 bar [3713psi]
Displacement per cycle:	24 cc [0.8oz]
Output @ 60 cycles / min:	1.4 L/m [0.4 gal/m]
Fluid inlet size:	FX-3/4" NPS (m), FXL-1/2" NPS (m)
Fluid outlet size:	FX: M14 x 1.5 (f); FXL: 3/8" BSPP (m) / 3/8" NPS (m)
Weight:	4.2 kg [9.2 lbs]
Wetted parts materials of construction:	Stainless Steel, Tungsten Carbide, PTFE, Polyethylene, Leather, Ceramic

FX4 & FXL4 - Fluid Section (Chevron seals)

Models: FX4## & FXL4##, ##=PL (PTFE/Leather), PP (PTFE), PU (PTFE/UHMWPE).

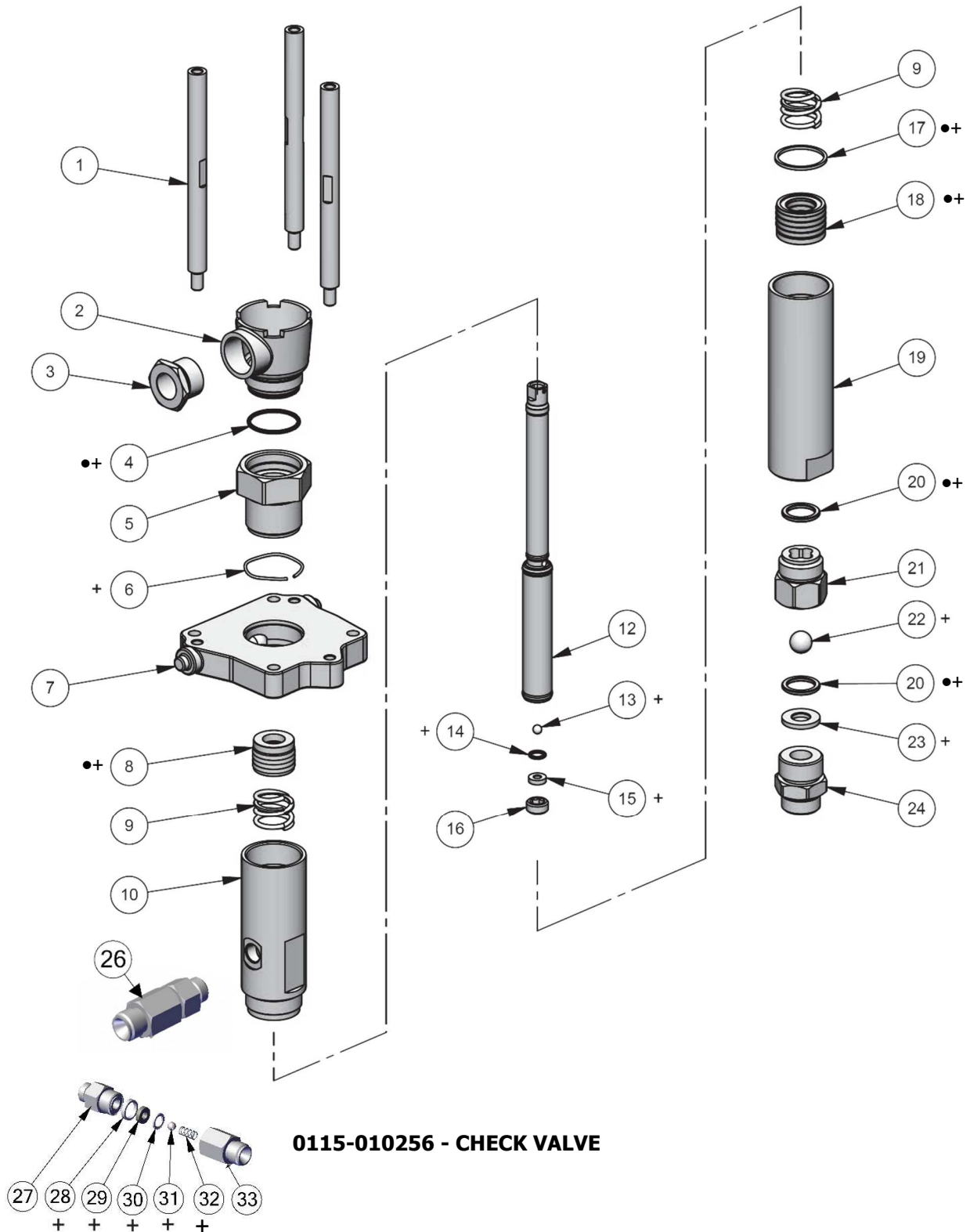

Item 3 is self-tapping into item 2.

		FX*4PL	FX*4PP	FX*4PU
•	Parts are included in Seal Kit:	0115-010221	0115-010223	0115-010225
+	Parts are included in Repair Kit:	0115-010222	0115-010224	0115-010388

FX4 & FXL4 - Fluid Section (Chevron seals)

Models: FX4## & FXL4##, ##=PL (PTFE/Leather), PP (PTFE), PU (PTFE/UHMWPE).

ITEM	PART NUMBER	DESCRIPTION	QUANTITY		
			FX4 & FXL4		
			PL	PP	PU
1	0115-010646	PUMP TIE ROD	3	3	3
2	0115-010059	SOLVENT CUP	1	1	1
3	0115-010060	SIGHT GLASS	1	1	1
4 •+	0115-010061	SOLVENT CUP SEAL	1	1	1
5	0115-010062	PACKING ADAPTER	1	1	1
6+	0115-010058	WAVE SPRING	1	1	1
7	0115-010204	ADAPTER PLATE MACHINING	1	1	1
8 •+	0115-010171	UPPER PACKING SET (PTFE/LEATHER)	1	-	-
	0115-010175	UPPER PACKING SET (PTFE/UHMW)	-	-	1
	0115-010206	UPPER PACKING SET (PTFE)	-	1	-
9	0115-010111	PACKING SPRING	2	2	2
10	0115-010055	UPPER PUMP TUBE	1	1	1
12	0115-010063	PUMP ROD	1	1	1
13 +	0114-014745	6mm UPPER BALL	1	1	1
14 +	0115-010065	ROD SEAT SEAL	1	1	1
15 +	0115-010066	ROD SEAT	1	1	1
16	0115-010067	ROD SEAT NUT	1	1	1
17 •+	0115-010064	PUMP TUBE SEAL	1	1	1
18•+	0115-010173	LOWER PACKING SET (PTFE/LEATHER)	1	-	-
	0115-010177	LOWER PACKING SET (PTFE/UHMW)	-	-	1
	0115-010207	LOWER PACKING SET(PTFE)	-	1	-
19	0115-010056	LOWER PUMP TUBE	1	1	1
20 •+	0115-010068	LOWER SEAT SEAL	2	2	2
21	0115-010057	LOWER BALL CAGE	1	1	1
22 +	0114-014237	15mm LOWER BALL	1	1	1
23 +	0115-010069	LOWER SEAT	1	1	1
24	0115-010149	INLET 3/4" NPS(m) FX4 ONLY	1	1	1
	0115-010070	INLET 1/2" NPS(m) FXL4 ONLY	1	1	1
26	0115-010256	FX4 CHECK VALVE ASSEMBLY - FXL4 ONLY	1	1	1
27	0115-010258	FLUID OUTLET FITTING	1	1	1
28 +	0115-010259	SEAL	1	1	1
29 +	0115-010066	ROD SEAT	1	1	1
30 +	0115-010065	ROD SEAT SEAL	1	1	1
31 +	0114-014745	6mm UPPER BALL	1	1	1
32 +	0115-010087	CHECK VALVE SPRING	1	1	1
33	0115-010257	CHECK VALVE HOUSING	1	1	1

FX4 & FXL4 - Fluid Section (U-cup seals)

Models: FX4UC & FXL4UC

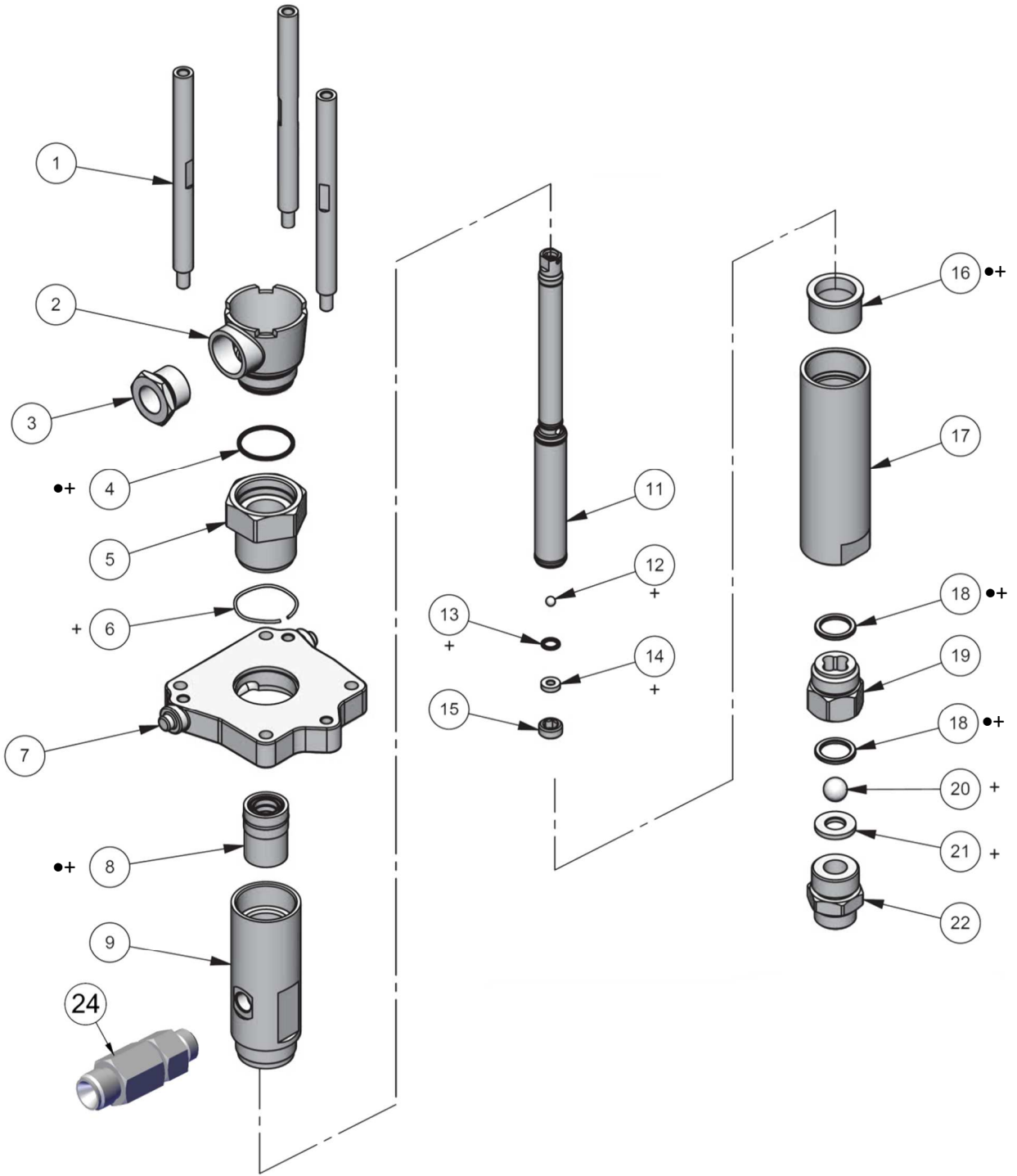

0115-010256 - CHECK VALVE

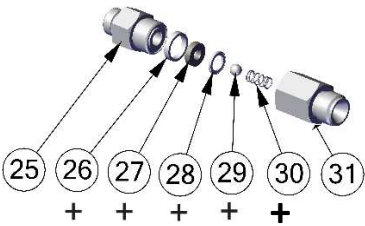

Item 3 is self-tapping into item 2.

FX4 & FXL4 - Fluid Section (U-cup seals)

Models: FX4UC & FXL4UC

ITEM	PART NUMBER	DESCRIPTION	QTY
1	0115-010646	PUMP TIE ROD	3
2	0115-010059	SOLVENT CUP	1
3	0115-010060	SIGHT GLASS	1
4 •+	0115-010061	SOLVENT CUP SEAL	1
5	0115-010062	PACKING ADAPTER	1
6 +	0115-010058	WAVE SPRING	1
7	0115-010204	ADAPTER PLATE MACHINING	1
8 •+	0115-010166	UPPER SEAL CARTRIDGE ASSEMBLY	1
9	0115-010055	UPPER PUMP TUBE	1
11	0115-010063	PUMP ROD	1
12 +	0114-014745	6mm UPPER BALL	1
13 +	0115-010065	ROD SEAT SEAL	1
14 +	0115-010066	ROD SEAT	1
15	0115-010067	ROD SEAT NUT	1
16 •+	0115-010169	LOWER SEAL CARTRIDGE ASSEMBLY	1
17	0115-010056	LOWER PUMP TUBE	1
18 •+	0115-010068	LOWER SEAT SEAL	2
19	0115-010057	LOWER BALL CAGE	1
20 +	0114-014237	15mm LOWER BALL	1
21 +	0115-010069	LOWER SEAT	1
22	0115-010149	INLET 3/4" NPS(m) FX4 ONLY	1
	0115-010070	INLET 1/2" NPS(m) FXL4 ONLY	1
24	0115-010256	FX4 CHECK VALVE ASSEMBLY - FXL4 ONLY	1
25	0115-010258	FLUID OUTLET FITTING	1
26 +	0115-010259	SEAL	1
27 +	0115-010066	ROD SEAT	1
28 +	0115-010065	ROD SEAT SEAL	1
29 +	0114-014745	6mm UPPER BALL	1
30 +	0115-010087	CHECK VALVE SPRING	1
31	0115-010257	CHECK VALVE HOUSING	1

• Parts are included in 0115-010219 Seal Kit (U-CUPS).

+ Parts are included in 0115-010220 Repair Kit (U-CUPS).

FX4 & FXL4 - Fluid Section (Chevron seals) - MAINTENANCE

Models: FX4## & FXL4##, ##=PL (PTFE/Leather), PP (PTFE), PU (PTFE/UHMWPE).

MAINTENANCE SYMBOLS

#	ITEM NUMBER
#	DISASSEMBLY ORDER <i>(Reverse for assembly)</i>
PG	PETROLEUM JELLY/GREASE
TS	THREAD SEALANT (PTFE tape)

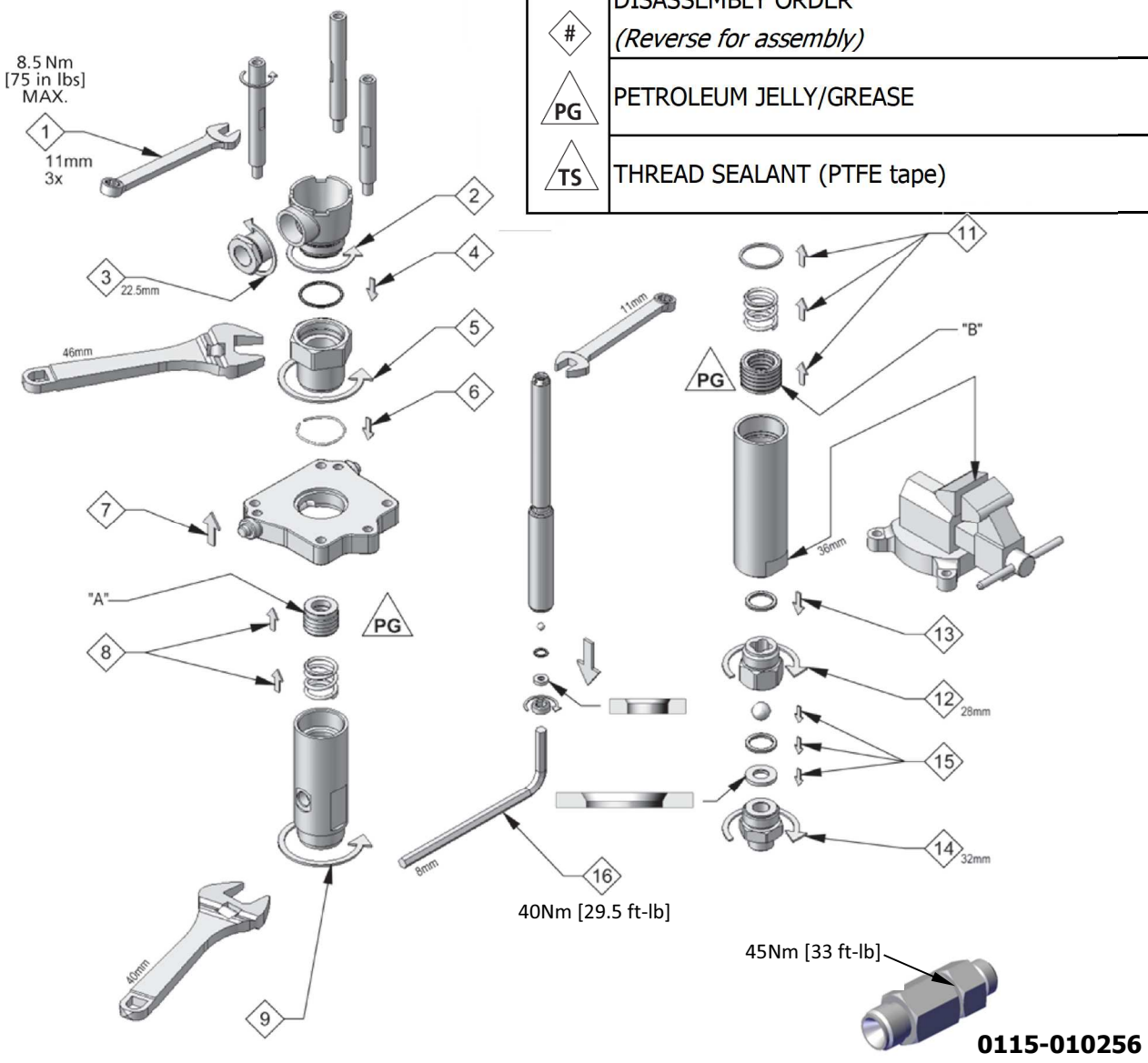

FX4 & FXL4 SEAL ORIENTATION

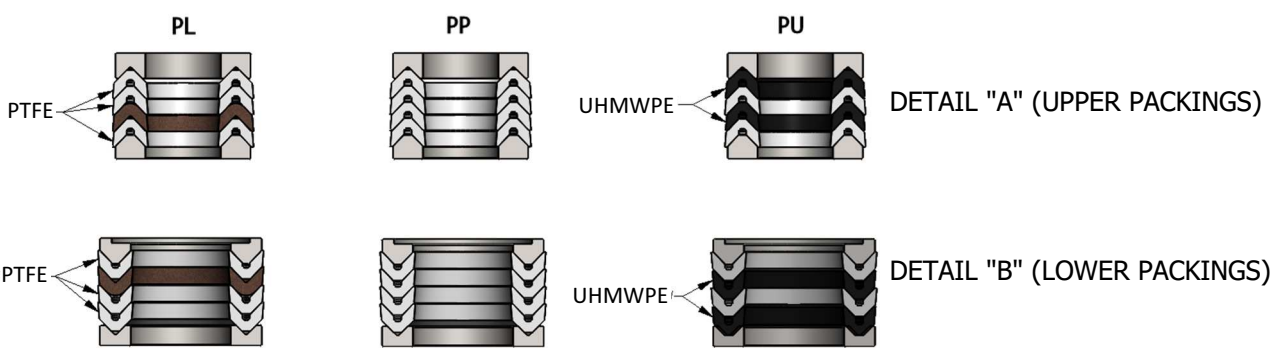

FX4 & FXL4 - Fluid Section (U-cup seals) - MAINTENANCE

Models: FX4UC & FXL4UC

MAINTENANCE SYMBOLS	
#	ITEM NUMBER
#	DISASSEMBLY ORDER <i>(Reverse for assembly)</i>
PG	PETROLEUM JELLY/GREASE
TS	THREAD SEALANT (PTFE tape)

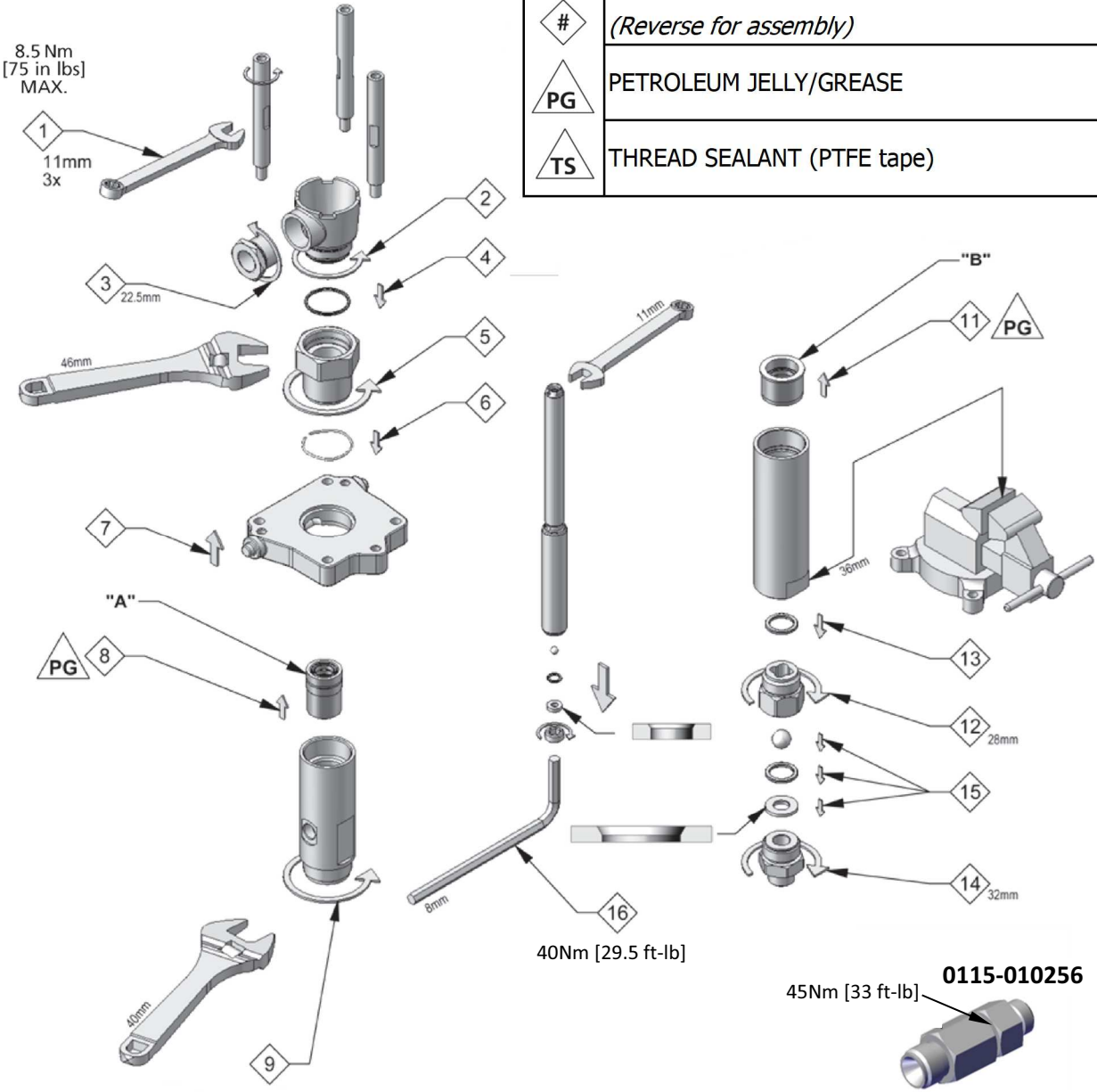

FX4 & FXL4 - SEAL ORIENTATION

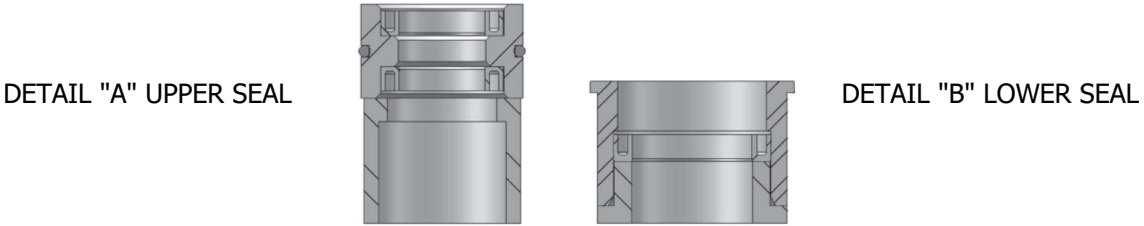

FLUID SECTION - TROUBLESHOOTING

PROBLEM	CAUSE	SOLUTION
Material in solvent cup	Worn or dirty upper packings.	Replace or clean upper packings as necessary.
Pump does not stop on the down stroke	Worn or dirty lower ball check.	Replace or clean the parts as necessary.
Pump does not stop on the up stroke	Worn or dirty upper ball check. Worn or dirty lower packings.	Replace or clean the parts as necessary.
Pump runs erratically	Blocked material siphon kit. Blocked inlet filter or strainer. Low material level.	Replace or clean the siphon kit. Replace or clean inlet filter or strainer. Replace or refill material container.
Pump runs, with no output	Loose connection in between pump and siphon assembly. Stuck lower ball.	Check that all connections are tight. Replace or clean the parts as necessary.

Packing Recommendation

Packing Material	Recommendation
PU (PTFE & UHMW)	Most materials
PL (PTFE & Leather)	High temperature applications
PP (PTFE)	UV and acid based materials
UC (U-Cups)	Low friction applications

NOTES

MX412 & MXL412 - CART MOUNTED PUMP

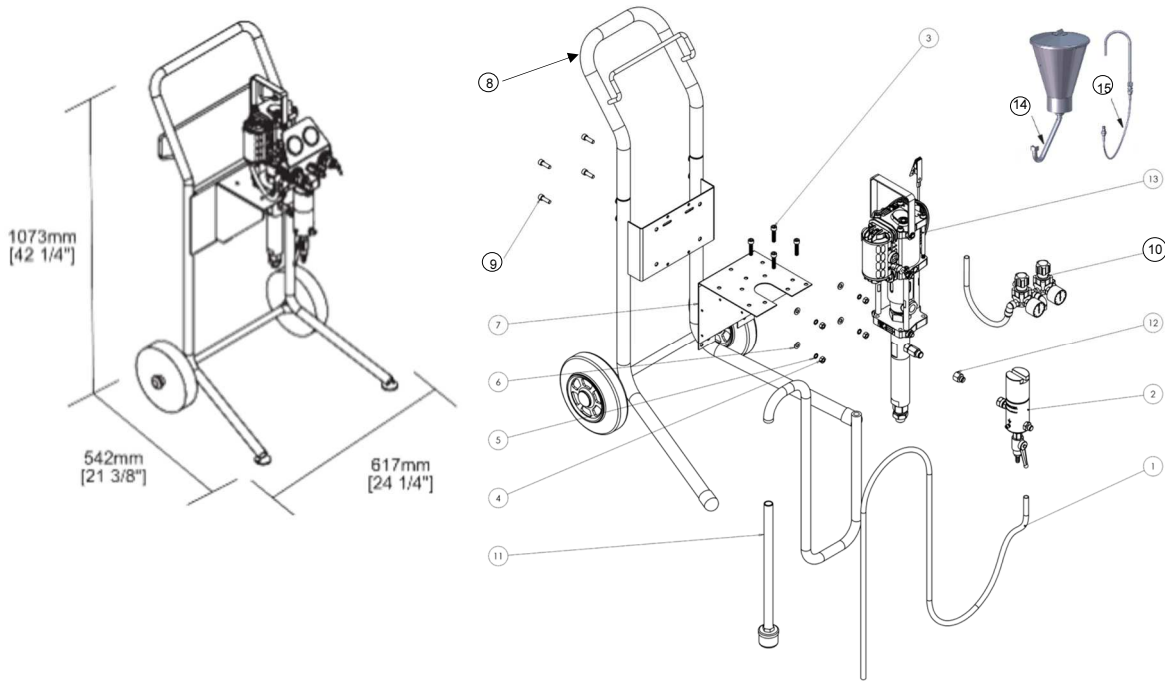

*= OPTIONS

ITEM	PART NUMBER	DESCRIPTION	QTY	
			MX	MXL
1	0110-009103	CONDUCTIVE NYLON HOSE	1*	
2	0110-009130	HP FILTER (100 mesh)	1*	
3	0115-010001	M8 x 35 SCREW	4	
4	0115-010030	M8 HEX NUT	4	
5	0115-010031	M8 LOCKWASHER	4	
6	0115-010035	M8 PLAIN WASHER	4	
7	0115-010179	WALL BRACKET	1	
8	0115-010186	CART	1	
9	0115-010227	M8 x 25 SCREW	4	
10	0115-010180	AIR CONTROL 2 REGULATORS & VALVE	1	-
	0115-010664	AIR CONTROL 2 REGULATORS	-	1
11	0115-010738	3/4" SUCTION HOSE (15 mesh)	1	-
	0115-010696	1/2" SUCTION HOSE (15 mesh)	-	1
12	0115-010705	3/8"F - 1/4"M OUTLET FITTING	-	1*
13	MX412**	MX412** BARE PUMP	1	-
	MXL412**	MXL412** BARE PUMP	-	1
14	0115-010726	HOPPER 6L [1.6 US Gal] [3/4" CONNECTION]	1*	-
	0115-010701	HOPPER 6L [1.6 US Gal] [1/2" CONNECTION]	-	1*
15	0114-009629	1/4" RETURN HOSE	1*	-
	0115-010712	1/4" RETURN HOSE	-	1*

MX412 & MXL412 - WALL MOUNTED PUMP

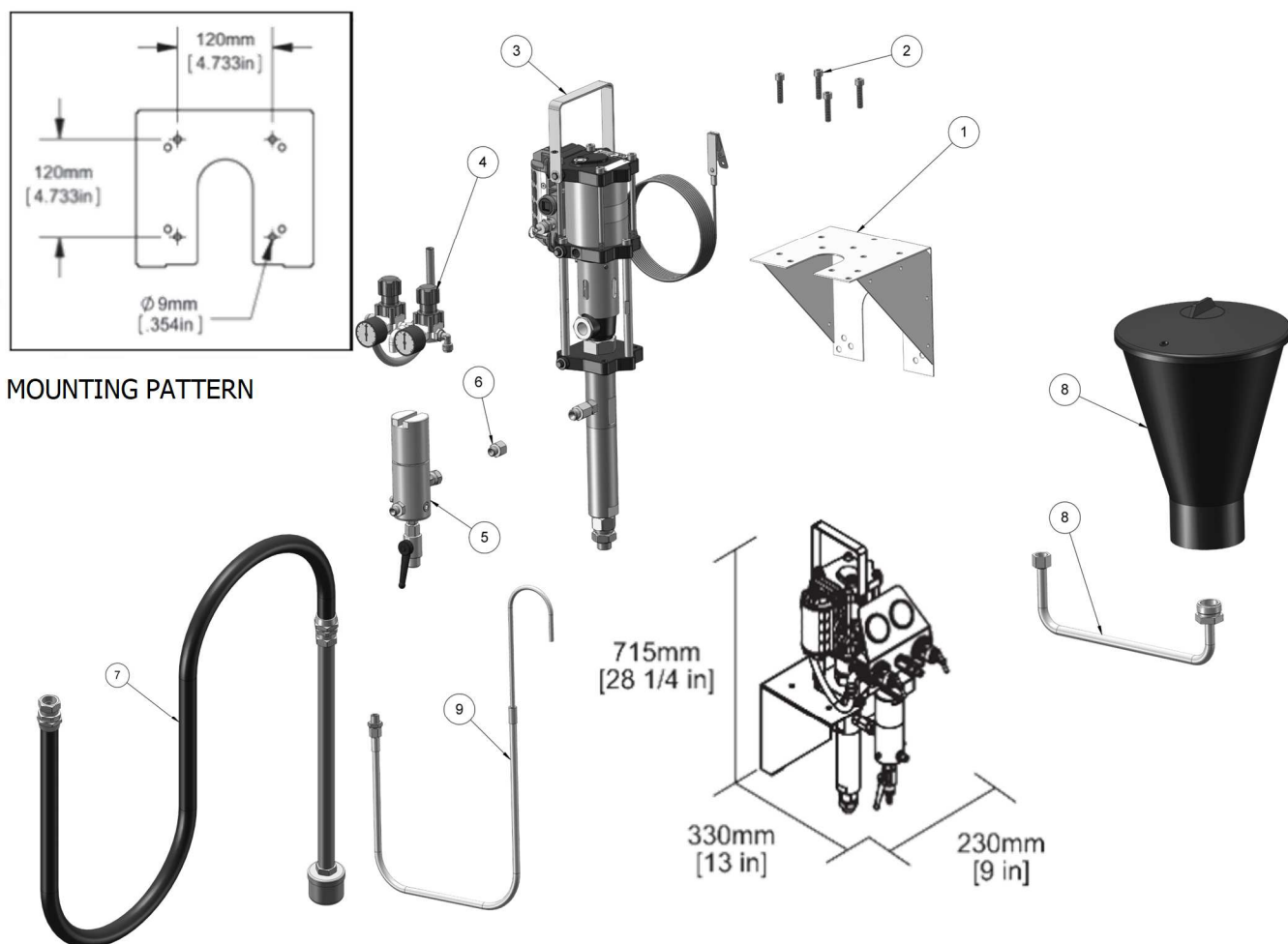

*= OPTIONS

ITEM	PART NUMBER	DESCRIPTION	QTY	
			MX	MXL
1	0115-010179	WALL BRACKET	1	
2	0115-010001	SCREW	4	
3	MX412**	MX412** BARE PUMP	1	-
	MXL412**	MXL412** BARE PUMP	-	1
4	0115-010180	AIR CONTROL 2 REGULATORS & VALVE	1	-
	0115-010664	AIR CONTROL 2 REGULATORS	-	1
5	0110-009130	HP FILTER (100 mesh)	1	1*
	0110-009103	CONDUCTIVE NYLON HOSE (not shown)	1	1*
6	0115-010705	3/8"F - 1/4"M OUTLET FITTING	-	1*
7	0115-010738	3/4" SUCTION HOSE (20 mesh)	1	-
	0115-010696	1/2" SUCTION HOSE (20 mesh)	-	1
8	0115-010726	HOPPER 6L [1.6 US Gal] [3/4" CONNECTION]	1*	-
	0115-010701	HOPPER 6L [1.6 US Gal] [1/2" CONNECTION]	-	1*
9	0114-009629	1/4" RETURN HOSE	1*	-
	0115-010712	1/4" RETURN HOSE	-	1*

MX412 & MXL412 - TRIPOD MOUNTED PUMP

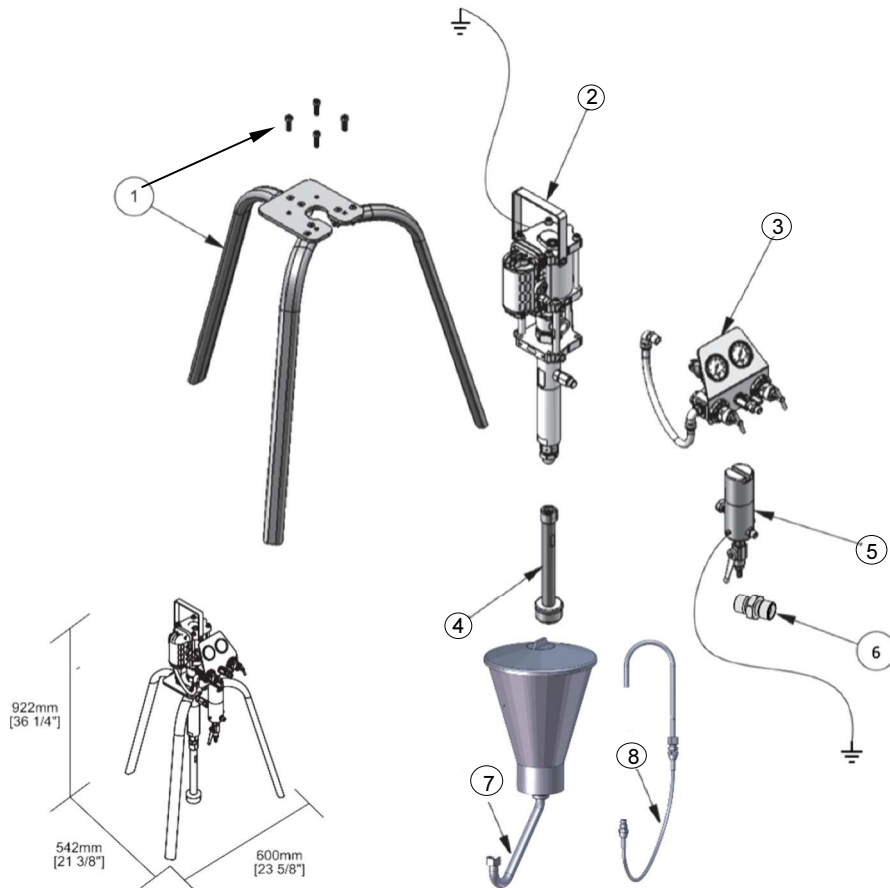

*= OPTIONS

ITEM	PART NUMBER	DESCRIPTION	QTY	
			MX	MXL
1	0115-010100	TRIPOD	1	
2	MX412**	MX412 BARE PUMP	1	-
	MXL412**	MXL412 BARE PUMP	-	1
3	0115-010180	AIR CONTROL 2 REGULATORS & VALVE	1	-
	0115-010664	AIR CONTROL 2 REGULATORS	-	1
4	0115-010670	3/4" SUCTION TUBE (50 mesh)	1	-
	0115-010699	1/2" SUCTION TUBE (50 mesh)	-	1
5	0110-009130	HP FILTER (100 mesh)	1	1*
	0110-009103	CONDUCTIVE NYLON HOSE (not shown)	1	1*
6	0115-010705	OUTLET FITTING	-	1*
7	0115-010726	HOPPER 6L [1.6 US Gal] [3/4" CONNECTION]	1*	-
	0115-010701	HOPPER 6L [1.6 US Gal] [1/2" CONNECTION]	-	1*
8	0114-009629	1/4" RETURN HOSE	1*	-
	0115-010712	1/4" RETURN HOSE	-	1*

ACCESSORIES

0114-009629 - 1/4" RETURN HOSE

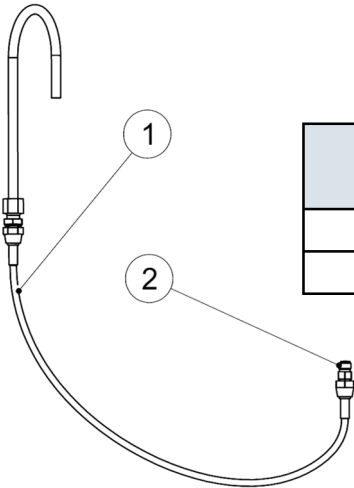

ITEM	PART NO.	DESCRIPTION	QTY
1	0115-010695	DUMP HOSE & TUBE	1
2	195913	1/4" FITTING	1

0115-010100 - TRIPOD

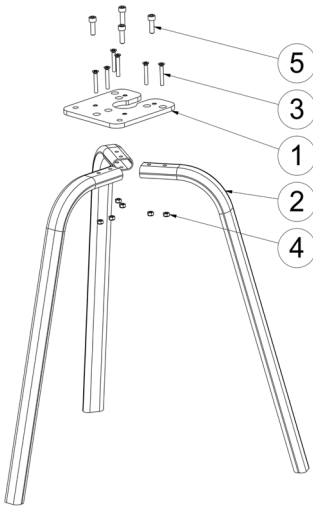

ITEM	PART NO.	DESCRIPTION	QTY
1	0115-010101	MOUNTING PLATE	1
2	0115-010210	TRIPOD LEG	3
3	0115-010212	FLAT HEAD SCREW	6
4	0115-010211	LOCKING NUT	6
5	0115-010227	M8 x 25 SCREW	4

0115-010738 - SUCTION HOSE (MX)

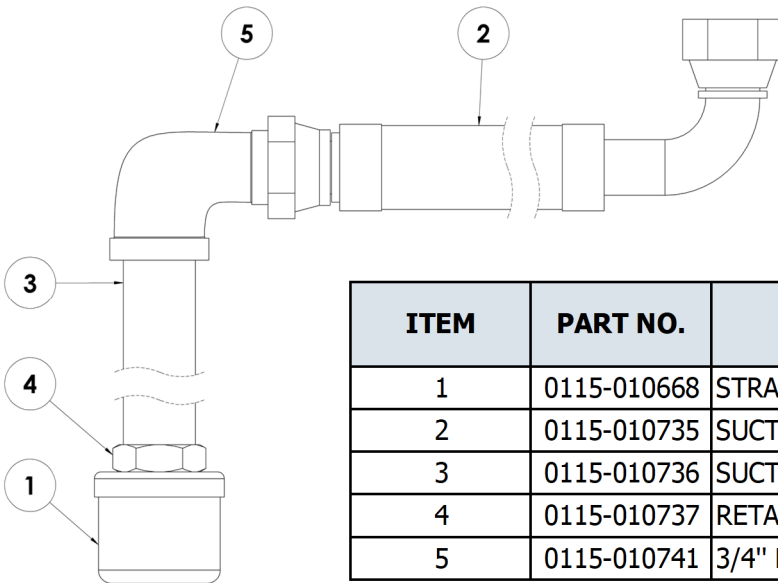

ITEM	PART NO.	DESCRIPTION	QTY
1	0115-010668	STRAINER 15 MESH	1
2	0115-010735	SUCTION HOSE (MX)	1
3	0115-010736	SUCTION TUBE	1
4	0115-010737	RETAINING RING	1
5	0115-010741	3/4" ELBOW	1

ACCESSORIES

0115-010664 - AIR CONTROL 2 REGULATORS (MXL)

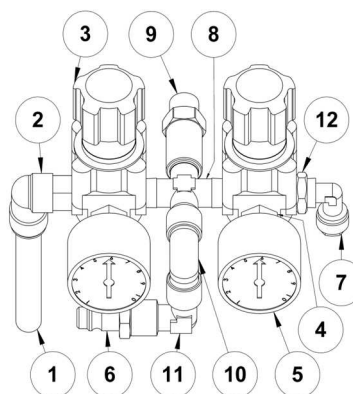

ITEM	PART NO.	DESCRIPTION	QTY
1	0115-010694	Ø12/Ø9mm NYLON TUBE	0.32m
2	0115-010666	Ø12mm-1/4" ELBOW	1
3	ZZ-3073	AIR REGULATOR	2
4	0114-019209	REDUCING BUSH	2
5	GA-382-P	PRESSURE GAUGE	2
6	MPV-10	QD STEM 1/4 BSP M	1
7	0115-010667	Ø8-1/4" ELBOW	1
8	0115-010665	1/4" CROSS	1
9	0115-010659	MOUNTING STUD	1
10	0114-020027	1/4" ELBOW	1
11	0115-010727	1/4" ELBOW	1
12	DVX-139	1/4" NUT	1

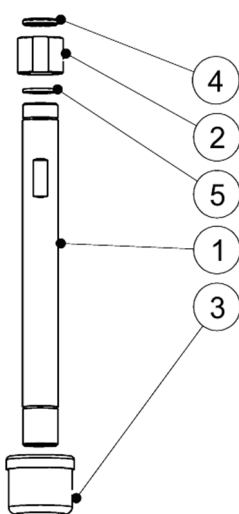

0115-010670 - SUCTION TUBE (MX)

ITEM	PART NO.	DESCRIPTION	QTY
1	0115-010105	SUCTION TUBE	1
2	0115-010104	ADAPTER	1
3	0115-010668	3/4" STRAINER 15 MESH	1
4	0115-010693	SEAL	1
5	0114-013834	SEAL	1

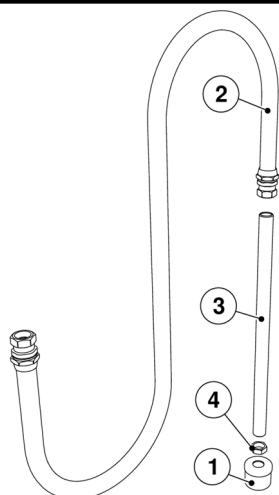

0115-010696 - 1/2" SUCTION HOSE (MXL)

ITEM	PART NO.	DESCRIPTION	QTY
1	0115-010704	1/2" STRAINER 30 MESH	1
2	0115-010698	1/2" HOSE	1
3	0115-010697	TUBE	1
4	0115-010728	NUT	1

ACCESSORIES

0110-009130 - HIGH PRESSURE FILTER

272 bar Max, 100 MESH
 3/8" BSP F INLET, 1/4" NPSM OUTLET

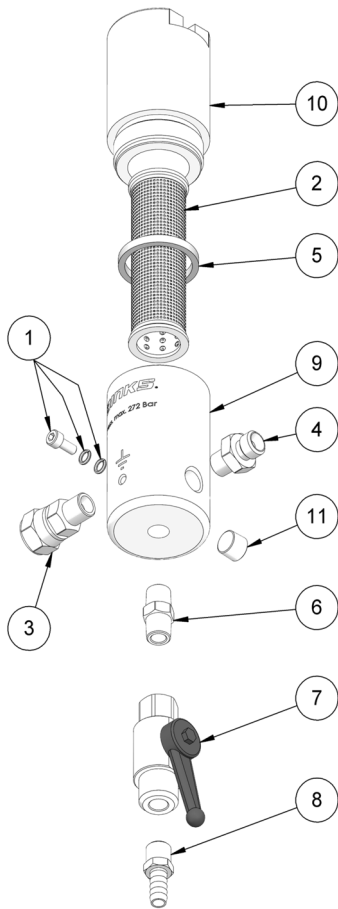

ITEM	PART NO.	DESCRIPTION	QTY
1	0110-009065	GROUNDING CLAMP	1
2	0110-009132	FILTER 100 MESH	1
3	0114-016058	3/8" BSP SWIVEL	1
4	0114-016059	1/4" NPSM NIPPLE	1
5	0114-016061	SEAL	1
6	0114-019090	1/4" BSP NIPPLE	1
7	0114-019091	BALL VALVE	1
8	0114-019985	HOSE NIPPLE	1
9	0115-010398	FILTER HOUSING	1
10	0115-010399	FILTER CAP	2
11	0115-010600	1/4" NPT PLUG	3
ADDITIONAL FILTERS			
0110-009131	50 MESH		
0110-009133	150 MESH		
0110-009134	200 MESH		

0115-010699 - 1/2" SUCTION TUBE (MXL)

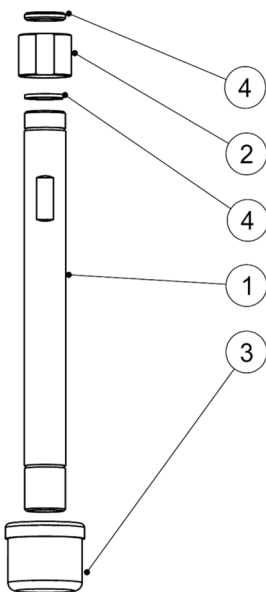

ITEM	PART NO.	DESCRIPTION	QTY
1	0115-010702	SUCTION TUBE	1
2	0115-010703	ADAPTER	1
3	0115-010704	3/4" STRAINER 15 MESH	1
4	0115-010165	SEAL	1

ACCESSORIES

0115-010180 - AIR CONTROLS (MX)

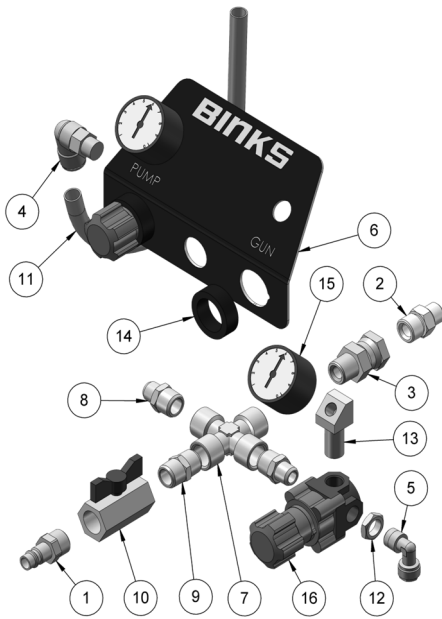

ITEM	PART NO.	DESCRIPTION	QTY
1	0110-009091	QD STEM	1
2	0115-010157	MOUNTING STUD	1
3	0115-010324	3/8" BSP SWIVEL	1
4	0115-010666	Ø12mm-1/4" ELBOW	1
5	0115-010667	Ø8mm-1/4" ELBOW	1
6	0115-010680	PANEL	1
7	0115-010681	3/8" BSP CROSS	1
8	0115-010682	3/8"-1/4" NIPPLE	2
9	0115-010683	3/8" BSP NIPPLE	1
10	0115-010684	BALL VALVE	1
11	0115-010694	Ø12/Ø9mm TUBE	0.32m
12	DVX-139	1/4" LOCKING NUT	1
13	DVX-56	GAUGE BLOCK	2
14	DVX-58	REGULATOR NUT	2
15	GA-382-P	PRESSURE GAUGE	2
16	ZZ-3073	AIR REGULATOR	2

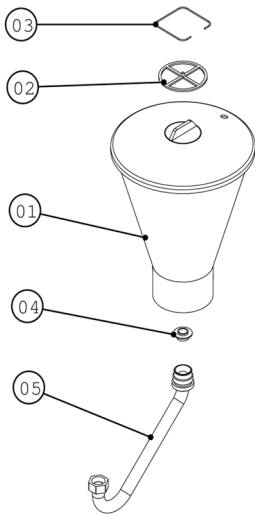

0115-010701 - HOPPER 6L [1.6 US Gal] [1/2" CONNECTION]

ITEM	PART NO.	DESCRIPTION	QTY
01	ZZ-2571	HOPPER	1
02	00-00-0002147	FILTER	1
03	00-00-0002148	TENSION RING	1
04	ZZ-2587	PTFE SEAL	1
05	0115-010707	SUCTION TUBE	1

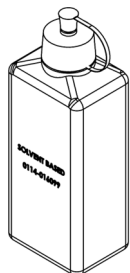

PUMP LUBRICATION

0114-016099	0.25l - LUBRICATION-SOLVENT BASED
0114-016100	0.25l - LUBRICATION-WATER BASED
0114-014871	0.5l - LUBRICATION-WATER BASED
0114-009433	0.5l - LUBRICATION-SOLVENT BASED

ACCESSORIES

0115-010200 - HIGH PRESSURE FILTER (PAIL)

272 bar Max, 100 MESH
 1/4" BSP M INLET , 1/4" NPT M OUTLET

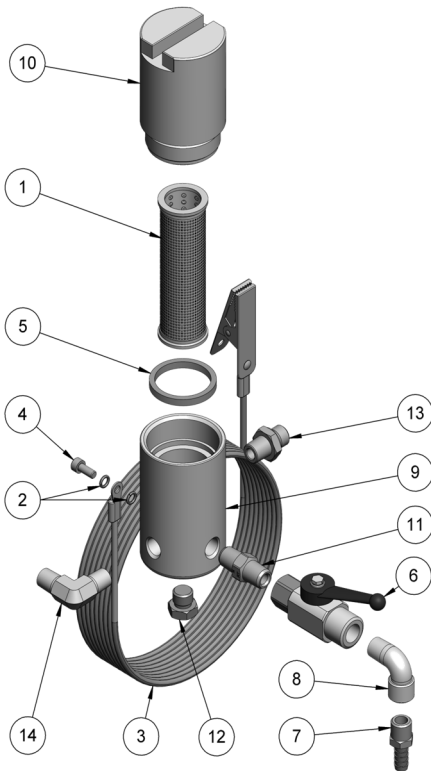

ITEM	PART NO.	DESCRIPTION	QTY
1	0110-009132	FILTER SCREEN 100 MESH	1
2	0114-009743	M5 LOCKWASHER	2
3	0114-011798	GROUND WIRE	1
4	0114-014179	M5 x 12mm SCREW	1
5	0114-016061	SEAL	1
6	0114-019091	BALL VALVE	1
7	0114-019985	HOSE CONNECTOR	1
8	0114-020027	1/4" BSP ELBOW	1
9	0115-010398	FILTER HOUSING	1
10	0115-010399	FILTER CAP	1
11	191969	1/4" BSP-NPT NIPPLE	1
12	192551	1/4" BSP PLUG	1
13	195913	1/4" BSP NIPPLE	1
14	20-2828	1/4" NPT ELBOW	1
ADDITIONAL FILTERS			
	0110-009131	50 MESH	
	0110-009133	150 MESH	
	0110-009134	200 MESH	

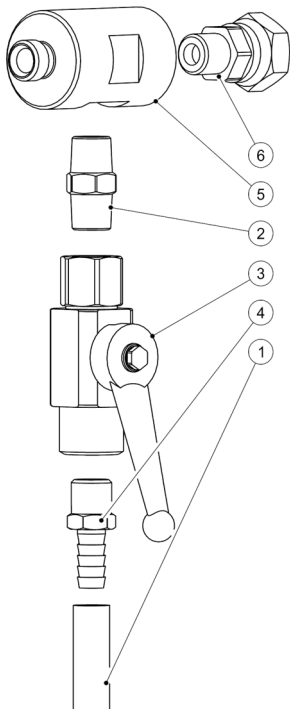

0115-010672 - DUMP VALVE KIT

272 bar Max
 1/4"NPSM F SWIVEL - 1/4" NPS M

ITEM	PART NO.	DESCRIPTION	QTY
1	0110-009103	DUMP HOSE	0.6
2	0114-019090	NIPPLE	1
3	0114-019091	BALL VALVE	1
4	0114-019985	HOSE CONNECTOR	1
5	0115-010673	MANIFOLD	1
6	0115-010674	SWIVEL NUT	1

ACCESSORIES

0115-010708 - AIR CONTROL 1 REGULATOR (MXL)

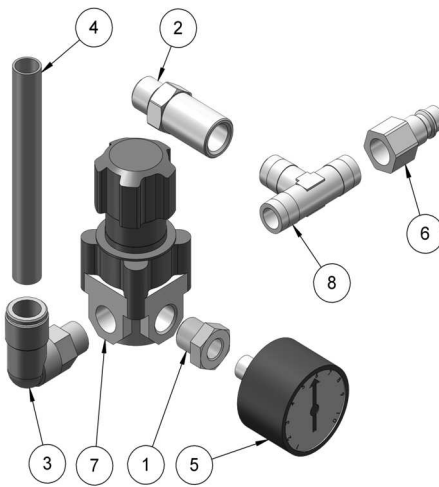

ITEM	PART NO.	DESCRIPTION	QTY
1	0114-019209	1/4"-1/8" REDUCING BUSH	1
2	0115-010659	MOUNTING STUD	1
3	0115-010666	Ø12mm-1/4" ELBOW	1
4	0115-010694	Ø9-Ø12mm TUBE	0.32m
5	GA-382-P	PRESSURE GAUGE	1
6	ZZ-2417	QD STEM	1
7	ZZ-3073	AIR REGULATOR	1
8	ZZ-3077	1/4" BSP FITTING	1

0115-010712 - 1/4" RETURN HOSE

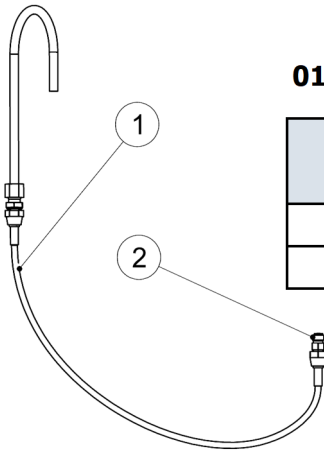

ITEM	PART NO.	DESCRIPTION	QTY
1	DVX-115	DUMP HOSE & TUBE	1
2	195913	1/4" FITTING	1

0115-010726 - HOPPER 6L [1.6 US Gal] [3/4" CONNECTION]

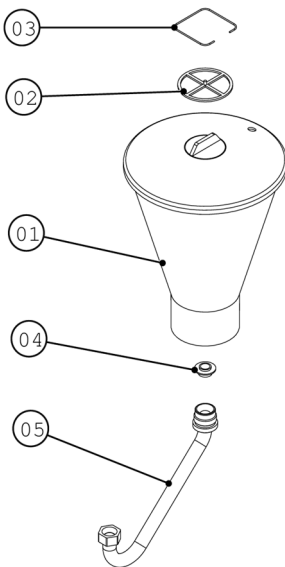

ITEM	PART NO.	DESCRIPTION	QTY
01	ZZ-2571	HOPPER	1
02	00-00-0002147	FILTER	1
03	00-00-0002148	TENSION RING	1
04	ZZ-2587	PTFE SEAL	1
05	0114-016041	SUCTION TUBE	1

NOTES

NOTES

WARRANTY POLICY

This product is covered by Binks materials and workmanship limited warranty.

The use of any parts or accessories, from a source other than Binks, will void all warranties. Failure to reasonably follow any maintenance guidance provided, may invalidate any warranty.

For specific warranty information please contact Binks.

For technical assistance or to locate an authorised distributor, contact one of our international sales and customer support locations below.

REGION	BINKS CONTACT
Americas	Tel: 1-888-992-4657
Europe, Africa, Middle East	Tel: +44 (0)1202 571 111
India	marketingroa@binks.com
China	Tel: +8621-3373 0108
Korea	Tel: +82313663303
Japan	Tel: +81 45 785 6421
Australia	Tel: +61 (0) 2 8525 7555

WARRANTY PAGE



Binks

Binks is a global leader in innovative finishing technologies. Binks reserves the right to modify equipment specifications without prior notice.

Binks®, DeVilbiss®, and Ransburg® are registered trademarks of Binks US, LLC.

© 2025 Binks US, LLC. All rights reserved.